

IFB Job No. 02-14, WK-08, Kapa‘a Homesteads 325’ Tanks, Two 0.5 MG Tanks,
Package B – Tanks Package, Kapa‘a, Kaua‘i, Hawai‘i

Questions/Answers/Material Substitution Requests
(from previous solicitation)

QUESTION 1: Please advise if any ground rings shall be added for the two new tanks to be constructed at the site as the electrical plans do not showcase this. Also, please advise if grounding shall be added to any metal piping or fencing for the new site and, if so, what sizing should this ground wire be.

Answer: A ground ring is not needed for the tanks. Grounding is not needed for the fence or metal piping.

QUESTION 2: Please see Drawing Page S-2, Note 8. Note 8 requests for a leakage test to be performed. Will water for the leakage test be provided by the Department or must the Contractor provide water for the leakage test?

Answer: Please refer to Section 2.5, Power and Water Supplies.

QUESTION 3: Spec Sections SP-11 11.03 C.d. "Conduits" and E.a.(1) "Conduits" specify the above ground conduit material type within the building line shall be rigid galvanized steel but there is no indication as to what conduit material shall be added within the vaults. Please advise if Rigid galvanized steel shall be used in the vaults or if PVC rigid galvanized steel shall be used instead.

Answer: PVC pipe can be used in the vaults.

QUESTION 4: Will there be a possibility of extending the laydown area? Could a small section of the area (the park) located across Ka'apuni road be used as a laydown, field office, or parking area?

Answer: Potential Offerors may coordinate with the County of Kaua'i, Department of Parks and Recreation to secure approval.

QUESTION 5: Drawing C-15 indicates Walls 1 & 2 are CRM however drawing S-16 indicates the walls are CMU. Please confirm which is correct.

Answer: Please follow the details on Sheet S-16.

QUESTION 6: Can the RFI deadline be extended?

Answer: The RFI deadline will not be extended.

QUESTION 7: Drawing E-3 indicates two ductbank runs tagged as Duct Section J and Duct Section K coming from the existing SCADA cabinet at the west side of Ornellas Tank. There is a third ductbank run above Duct Sections J and K turning to a pullbox and an existing SCADA pole in the Control Valve No. 2 & No. 3 location without a tag or Duct and Wire Schedule information. The same ductbank run exists on Drawing E-4 in Detail 2 south of Control Valve 2.

IFB Job No. 02-14, WK-08, Kapa‘a Homesteads 325’ Tanks, Two 0.5 MG Tanks,
Package B – Tanks Package, Kapa‘a, Kaua‘i, Hawai‘i

Questions/Answers/Material Substitution Requests
(from previous solicitation)

Please clarify the proposed work to be completed at this run as it is shown to be new on drawing page E-3.

Answer: The conduit that is not labeled and the handhole to the existing Scada pole does not need to be provided.

QUESTION 8: Please see Act 17 Apprenticeship Form that was provided within the contract documents. In speaking with the unions, they have found that the form looks to be different from the standard format [They say the listing (4.1, 4.2, ... etc) is not the same as it would typically be]. They would like to know if this Act 17 Form is an acceptable form to be turned in with the bid.

Answer: Act 17 form is an acceptable form.

QUESTION 9: Drawing E-3 portrays liquid-tight flexible metal conduit extending from junction boxes in Tanks A and B to all Tank Hatch Security Switches "HS", typical of 12. Also on Drawing E-3, liquid-tight flexible metal conduit extends from junction boxes on the south end of Tank A and the east end of Tank B to Tank Stairs Security Alarm Switches "GS2" and "GS3". Detail 3 on Drawing E-7 and Detail 1 on Drawing E-8 indicate stainless steel armored cable instead of liquid-tight flexible metal conduit. Please confirm whether liquid-tight flexible metal conduit or armored cable is required.

Answer: Contractor shall use the stainless steel armored cable for the tank hatch security.

QUESTION 10: From Profile Views in Drawing C-12, the 16" DIP Washout Lines from Tanks A and B that are encased in concrete were specified as Class 53 then it changes to Class 52 once the pipes are not encased, but the 16" DIP Overflow Line from Tanks A and B that are encased in concrete were specified as Class 52 from Profile View in Drawing C-12 and remains Class 52 once the pipe is not encased; Drawing S-8 Detail 1 specified the encased 16" DIP Overflow Line as Class 53. Please clarify Class number (thickness) of the 16" DIP Washout Lines and Overflow Lines when it's encased in concrete and when it's not encased in concrete.

Answer: All concrete encased pipe must be Class 53. Class 52 is acceptable for non-concrete encased pipe.

QUESTION 11: Drawing C-20, Water Line "A", BL A, Station 2+82.42 indicates to use Concrete Block with Structural Struts but did not specify which Detail to use from the Structural Drawings. Please specify which detail to use.

Answer: Use Detail B shown on S-18.

QUESTION 12: Drawing C-9 Notes 5 and 6 both referenced Sheet C-30 for Concrete Block details but there's nothing shown in C-30 that's regarding Concrete Blocks. Please clarify which

IFB Job No. 02-14, WK-08, Kapa‘a Homesteads 325’ Tanks, Two 0.5 MG Tanks,
Package B – Tanks Package, Kapa‘a, Kaua‘i, Hawai‘i

Questions/Answers/Material Substitution Requests
(from previous solicitation)

Sheet/Detail to use for Concrete Thrust Beam for Reducer and for Concrete Block with Structural Struts besides Sheets S-17 and S-18.

Answer: See Sheet C-29 for Typical Thrust Block with structural Struts for Connections and Concrete Trust Beam for Reducer.

QUESTION 13: Please confirm if all underground Gate Valves for the Water Lines are MJ and if they need Anchor Block as shown on Drawing C-29.

Answer: All gate valves must be provided with Gate Valve Anchor Block. Gate valves shall be push on or MJ unless otherwise called out on the drawings.

QUESTION 14: Please provide the manufacturer name of the existing RTU hardware and software being currently used at the site.

Answer: Schneider Electric SCADAPak32P and SCADAPak32 PLCs and Wonderware Software.

QUESTION 15: Based on Appendix B - General Provisions - Section 5.5 Differing Site Conditions, page 38, Contractor shall carry the cost and expense for any unknown conditions. This unknown cost to be carried in the bid will cause DOW to pay a significant amount due to Contractor's carrying additional money in their bids for work that may or may not actually happen for this unknown risk transferred to the Contractor. In order to minimize the cost that DOW will need to pay for unforeseen conditions that the Contractor is carrying in their bid and could end up not spending, please consider the below modification to the General Provisions as well as creating an allowance for this item as a "Contingency Allowance" so that DOW will only need to pay for actual cost for unforeseen conditions and any allowance not spent would be returned to DOW in lieu of the Contactor seeing additional gains for this unused contingency in their bid.

Please see Appendix B - General Provisions - Section 5.5, Page 38. Please consider replacing the language in Section 5.5 Differing Site Conditions with the following:

"The CONTRACTOR shall promptly notify the DEPARTMENT of the following work site conditions (hereinafter called differing physical conditions), in writing, upon their discovery and before they are disturbed:

1. Subsurface or latent physical conditions differing from those indicated by information about the site made available to Bidders prior to the deadline for submitting bids;
2. Unknown physical conditions of any unusual nature, differing materially from those ordinarily encountered and generally recognized as inherent in work of the character being performed.

DEPARTMENT will promptly investigate conditions which appear to be differing physical conditions. If the DEPARTMENT determines that the conditions are differing physical conditions and will materially affect costs, a Change Order will be issued adjusting the

IFB Job No. 02-14, WK-08, Kapa‘a Homesteads 325’ Tanks, Two 0.5 MG Tanks,
Package B – Tanks Package, Kapa‘a, Kaua‘i, Hawai‘i

Questions/Answers/Material Substitution Requests
(from previous solicitation)

compensation for such portion of the Work in accordance with General provision Section 5.3 Modifications To The Work. If the DEPARTMENT determines that conditions are differing physical conditions and they will materially affect performance time, the CONTRACTOR, upon submitting a written request, will be granted an extension of time subject to the provisions noted in General Provisions Section 5.3 Modifications To The Work and Section 8.3 Default, Delay, and Time Extensions."

Answer: Thank you for the suggestion. The Department of Water will consider this for future projects but will leave the referenced language in Appendix B as is for this project.

QUESTION 16: In Drawing C-17 from the List of Material for Control Valve Assembly 3 (6" Electronic Control Valve Detail), Item #8 indicates a 12"x6" reducer MJ with concrete thrust beam for reducer, but Call-out 8 in that detail can't be found. Please confirm that this 12"x6" reducer is the same item from C-09 Water Line C Station 0+12.72.

Answer: Confirming that the 12"x6" reducer is the same item from C-09 Water Line C Station 0+12.72.

QUESTION 17: In Drawing C-17 from the Control Valve Assemblies 2 and 3 details, there's a W1" arrow leading to the Control Valves. Please clarify where this line is coming from and what pipe material it is.

Answer: The W1" is copper pipe used to provide water from the 580 system to operate the ClaValves.

QUESTION 18: In Drawing C-17 from the List of Material for Temporary PRV Vault, Control Valve Assembly 2, and Control Assembly 3 details, hose bibbs were specified as 3/4", but from the Pressure Relief Valve Assembly for PRV Station detail in the same Drawing Sheet, hose bibb is specified as 1". Please clarify the size of Hose Bibbs.

Answer: On Sheet C-17 Pressure Relief Valve Assembly for PRV Station, replace 1" hose bibb with "3/4" hose bibb without check, threaded with cap (smooth nose) and 1" x 3/4" bushing".

QUESTION 19: Please clarify if there is a spare breaker or power source that can be utilized for temporary power for an office trailer.

Answer: Contractor to coordinate temporary power with KIUC for the officer trailer.

QUESTION 20: In Drawing C-17 from the Control Valve Assemblies 2 and 3 details, it calls out "Wall Sleeve (TYP) See Detail Sheet C-16" but in C-16 Wall Sleeve Detail, there's no Wall Sleeve shown in the detail. Please confirm if need Wall Sleeves or just patch with grout; and if Wall Sleeves are needed, please specify wall sleeve material.

IFB Job No. 02-14, WK-08, Kapa‘a Homesteads 325’ Tanks, Two 0.5 MG Tanks,
Package B – Tanks Package, Kapa‘a, Kaua‘i, Hawai‘i

Questions/Answers/Material Substitution Requests
(from previous solicitation)

Answer: Wall sleeve is not required. The pipe may be grouted in place at wall penetration.

QUESTION 21: Please specify where the Chlorination Box Detail in Drawing C-30 is for.

Answer: Chlorination box detail is not being used on this project.

QUESTION 22: In Drawing C-14, Profile View for Water Line E at Station 0+00, there's a pipe (about 10 ft long) leading from the 16" Cap to the 4" CO. Please specify what material is needed for the 4" pipe.

Answer: Use 4" Ductile Iron Pipe.

QUESTION 23: Please confirm if a field office is required to be provided for DOW or can an allowance be created to let the Department determine if one should be required or not after bidding.

Answer: A field office is required as identified in SP-15.

QUESTION 24: Please provide pricing for the building permit required from the Department of Public Works mentioned in the Solicitation Documents - Section 2.3 Permits Page 18.

Answer: See Section SP-21 - Permits for information on Permits and fees.

QUESTION 25: In the water system standards 303.02 D.6 for yard finish material it states that Yard finishing material shall be lightly rolled to a smooth, even plane with suitable compaction as approved by the Manager. Please define suitable compaction.

Answer: Yard finishing material refers to topsoil for planting. Yard finishing material shall be lightly rolled to a smooth, even plane with suitable compaction, ready to receive planting.

QUESTION 26: In the water system standards 303.02 C.b it calls for side slopes to be 1.5:1 or otherwise noted in the drawings. Grading notes on C-1 note 5 it states "ALL SLOPES SHALL BE 2:1 OR FLATTER". Please confirm that all slopes are to be cut at 2:1 or flatter.

Answer: Slopes shall be 2:1 or flatter.

QUESTION 27: In the water system standards division 303.02 H.6 its states that required soil for fill, backfill, trench filling, etc shall be approved by manager. It doesn't reference a spec for the material. Please provide spec for fill material.

Answer: On-site material is suitable for trench backfill.

IFB Job No. 02-14, WK-08, Kapa‘a Homesteads 325’ Tanks, Two 0.5 MG Tanks,
Package B – Tanks Package, Kapa‘a, Kaua‘i, Hawai‘i

Questions/Answers/Material Substitution Requests
(from previous solicitation)

QUESTION 28: The Specification Section SP-12 12.03 B. "Programming" implies that the RTU supplier and Contractor are to supply a new RTU in addition to complete programming and documentation. In Drawing E-7, Detail 4 calls out "New cables to existing RTU". Please clarify if the Contractor is to supply a new RTU.

Answer: Specification Section SP-12.03 B only requires to provide the complete programming and documentation for the RTU. No new RTU to be installed.

QUESTION 29: Please clarify the existing SCADA integrator and possible integrators that are preferable or especially required for utilization.

Answer: The existing SCADA contractor is Glenmount Global Solutions.

QUESTION 30: In the job plans sheet C-11 it depicts a well on the NE side of the existing Tank. This well has a note that says "well by others" please specify if this work will be done before or after the scope of work for this project.

Answer: Well construction at the project site will be done after this project.

QUESTION 31: In the job plans sheet C-11 under Profile - Wall 2 it calls out sheet C-14 for details, please confirm that the correct sheet should be sheet C-15.

Answer: See Sheet S-16 for wall details.

QUESTION 32: Note 6 on Drawing No. S-1, states that "it is very common that hard rock cores exist within this type of soils. The hardness and extent of the rock core might vary significantly at different locations. Therefore, some difficult drilling conditions will likely be encountered at the Project Site and shall be expected." In order to minimize the cost for DOW from drillers assuming that all the drilling will be through hard rock, it is common to include a unit price item or allowance in the Offer Schedule for drilling obstructions with an assumed quantity so that DOW only pays for the cost of the actual impacts from obstructions and not the full amount of drilling. These unit price items are typically either on an hourly unit or a linear foot unit. Please add a unit price item or allowance for drilling obstruction encountered and an assumed quantity to provide a uniform basis for comparing bids and minimize the cost to DOW for this unknown risk.

Answer: No unit price item or allowance will be added for hard rock core drilling.

QUESTION 33: In Drawing C-16 from the Control Valve Assembly 1 Detail, Note 2 indicates that all flanged joints shall have silicon bronze bolts, but in Drawing C-17 from the Temporary PRV Vault Detail, Note 5 indicates that all fastening hardware shall be 316 Stainless Steel. The

IFB Job No. 02-14, WK-08, Kapa‘a Homesteads 325’ Tanks, Two 0.5 MG Tanks,
Package B – Tanks Package, Kapa‘a, Kaua‘i, Hawai‘i

Questions/Answers/Material Substitution Requests
(from previous solicitation)

Water System Standards 2022 Section 202.01.F indicates that all bolts and nuts shall be either silicon bronze or 316 stainless steel. Please confirm if we really have to use different fastening materials for Control Valve Assembly 1 compared to the Temporary PRV; and please clarify which fastening material to use for Control Valve Assemblies 2 and 3 in Drawing C-17.

Answer: Bolts and nuts shall conform to Water System Standards 2002, Section 202.01.F.

~~**QUESTION 34:** Several key subcontractors have declined to bid due to another large project in Hawaii that is bidding on the same day. We respectfully request bid date to be moved to April 21, 2023.~~

~~*Answer:* Bid Opening date has been updated to April 28, 2023 (SEE ADDENDUM NO. 2).~~

~~**QUESTION 35:** Bid item 28 states in the last sentence to include "Concrete Caissons for two tanks, in place complete", however it appears that all the drilled shafts are accounted for in Bid Items 29-31. Please clarify what to include in bid item 28 for the concrete caissons.~~

~~*Answer:* For Item 28, delete, "Concrete Caissons for two tanks, in place complete." Concrete Caisson cost are included in Items 29, 30, and 31.~~

~~**QUESTION 36:** Please clarify what lengths the trial shafts will be and how much the test load will be. The production shafts have different load capacities so it's not clear what the test load should be. The proposed 75' test shaft is longer than the production shafts, which means the test shaft strength may not be indicative of the production pile strength.~~

~~*Answer:* See attached detail sheet and revised proposal form.~~

QUESTION 37: Please confirm that bidders should base their bids off only the hazardous/contaminated materials/soil that is shown or called out in the Contract Documents and anything discovered that is not shown will be handled per General Provisions 5.3.B and 5.4.

Answer: "If additional hazardous or contaminated material is encountered, the cost to handle the material will be per General Provisions 5.3.B and 5.4."

IFB Job No. 02-14, WK-08, Kapa‘a Homesteads 325’ Tanks, Two 0.5 MG Tanks,
Package B – Tanks Package, Kapa‘a, Kaua‘i, Hawai‘i

Questions/Answers/Material Substitution Requests
(from previous solicitation)

MATERIAL SUBSTITUTION REQUEST NO. 1: APPROVED (see attached)

Comment: Item No. 4, 1080 SY, 12” thick grass cell base, in place complete.

MATERIAL SUBSTITUTION REQUEST NO. 2: APPROVED (see attached)

Comment: Plan C-16 “Venturi Meter Differential Pressure Transmitter Hook-up and Mounting Schematic”

MATERIAL SUBSTITUTION REQUEST NO. 3: DENIED (see attached)

Comment: Horizontal access door information provided does not show double leaf access.



TRUEGRID® vs Geoblock® 5150

TRUEGRID® is committed to providing the best possible solution for permeable paving in all residential, commercial, and industrial applications. TRUEGRID® is The World's Strongest Permeable Paver and is unmatched in engineering, performance, and longevity.

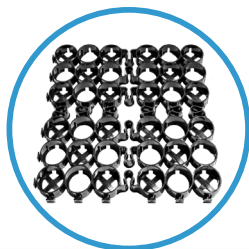

	TRUEGRID® PRO PLUS®	TRUEGRID® PRO LITE®	Geoblock® 5150
Compressive Strength	17,729 psi 12,465 t/m ² ✓	17,729 psi 12,465 t/m ² ✓	7,058 psi 4962 t/m ² ✗
Tensile Strength	2116 psi 14589 kPa ✓	1335 psi 9205 kPa ✓	Not Tested / Disclosed ✗
Unit Configuration	Rigid and Flexible ✓	Rigid and Flexible ✓	Rigid ✗
Easy Unit Placement - No Special Patterns for Traffic Directions	Yes ✓	Yes ✓	No ✗
Self-Anchoring - Does Not Require Slope/Perimeter Anchors	Yes ✓	Yes ✓	No ✗
Available Markers/Delineators	Yes ✓	Yes ✓	No ✗
Installation Time	1000 sq ft / hr 100 m ² / hr ✓	1000 sq ft / hr 100 m ² / hr ✓	500 sq ft / hr 50 m ² / hr ✗
Dimensions	1.8 in x 24 in x 24 in 4.6 cm x 61 cm x 61 cm	1 in x 24 in x 24 in 2.5 cm x 61 cm x 61 cm	2 in x 20 in x 40 in 5 cm x 50 cm x 100 cm

TRUEGRID® | TRUE ADVANTAGES

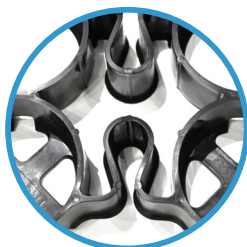

TRUEGRID® S-Flex joints move with freeze-thaw cycles & heaving soils.

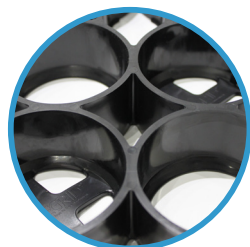

Co-joined cylinder walls provide extreme compressive strength – The World's Strongest.



TRUEGRID® is self anchoring with X-Anchors. No additional staking needed.



Three-point locking tabs secure the units together with high tensile strength.



100% recycled high impact plastic with UV inhibitors provide a long lifespan: 25-60+ years.

All information provided is deemed reliable at the time of publication, but is not guaranteed. TRUEGRID®, PRO PLUS® & PRO LITE® are registered trademarks of Airlite Plastics™. Geoblock® 5150 is a registered trademark of Presto Products Company. TRUEGRID: The intellectual property leader in permeable paver technology. US Pat. No's: 8,734,049; 9,670,624; 9,617,698; 9,909,264; 9,909,266; 10,072,383; D792,987. Additional US and Foreign Patents Pending. © Copyright 2019 TRUEGRID® Pavers. All Rights Reserved.

IFB Job No. 02-14, WK-08
Material Substitution Request No. 2
(APPROVED-35 pages)



PO Box 720 * Kula, HI 96790 Tel: (808) 235-6307
Email: bob@cbchawaii.com

February 17, 2023

Department of Water, County of Kauai
Engineering Division
ATTN: Jason Kagimoto, PE - Procurement Officer
4398 Pua Loke Street
Lihue, HI 96766

Subject : Request for Substitution
Project Title : **WK-08, Kapa'a Homesteads 325' Tanks – Job No. 02-14**

We hereby submit for substitution, with attached technical brochures, specifications and statement of variances for your review and approval for the items shown below.

SECTION NUMBER	BRAND SPECIFIED	SUBSTITUTE OR ALTERNATE	VARIANCE
SP-10.02.F Press.Transmitter	Rosemount 3051T	ABB 266DSH	None

Note: ABB 266DSH DP transmitter with 3-valve manifold is called out in project Plan C-16 item #15. The PFS Venturi Flow Metering Systems includes as its package, the Stainless Steel NEMA 4X enclosure with window along with its stand as described on Plan C-16 "VENTURI METER DIFFERENTIAL PRESSURE TRANSMITTER HOOK-UP AND MOUNTING SCHEMATIC".

I certify that substitution request of the above item meets as equivalent to the specified equipment in size, function and operational requirements.

Sincerely,

Bob Lake

Bob Lake
CBC Inc.

ABB MEASUREMENT & ANALYTICS | DATA SHEET

266DSH

Differential pressure transmitters



Measurement made easy

Engineered solutions for all applications

Base accuracy

- from 0.06 % of calibrated span (optional 0.04 %)

Reliable sensing system coupled with very latest digital technologies

- provides large turn down ratio up to 100:1

Comprehensive sensor choice

- optimize in-use total performance and stability

10-year stability

- 0.15 % of URL

Flexible configuration facilities

- provided locally via local LCD keypad

New TTG (Through-The-Glass) keypad technology

- allows quick and easy local configuration without opening the cover, even in explosion proof environments

IEC 61508 certification

- version for SIL2 (1oo1) and SIL3 (1oo2) applications

PED compliance

- Category III for PS > 20 MPa, 200 bar
- Sound Engineering Practice (SEP) for PS ≤ 20 MPa, 200 bar

~~WirelessHART version~~

- ~~• the battery powered solution compliant to IEC 62591~~

Best-in-class battery life

- up to 10 years @ 32 s update time
- in-field replaceable

Product in compliance with Directive 2011/65/UE (RoHS II)

In-built advanced diagnostics

Specification – functional

Range and span limits

Sensor code	Upper range limit (URL)	Lower range limit (LRL)	Minimum measuring span
A	1 kPa 10 mbar 4 inH2O	-1 kPa -10 mbar -4 inH2O	0.05 kPa 0.5 mbar 0.2 inH2O
B	4 kPa 40 mbar 16 inH2O	-4 kPa -40 mbar -16 inH2O	0.2 kPa 2 mbar 0.8 inH2O
E	16 kPa 160 mbar 64 inH2O	-16 kPa -160 mbar -64 inH2O	0.54 kPa 5.4 mbar 2.16 inH2O
F	40 kPa 400 mbar 160 inH2O	-40 kPa -400 mbar -160 inH2O	0.4 kPa 4 mbar 1.6 inH2O
H	160 kPa 1600 mbar 642 inH2O	-160 kPa -1600 mbar -642 inH2O	1.6 kPa 16 mbar 6.4 inH2O
M	600 kPa 6 bar 87 psi	-600 kPa -6 bar -87 psi	6 kPa 0.06 bar 0.87 psi
P	2400 kPa 24 bar 348 psi	-2400 kPa -24 bar -348 psi	24 kPa 0.24 bar 3.5 psi
Q	8000 kPa 80 bar 1160 psi	-8000 kPa -80 bar -1160 psi	80 kPa 0.8 bar 11.6 psi
S	16000 kPa 160 bar 2320 psi	-16000 kPa -160 bar -2320 psi	160 kPa 1.6 bar 23.2 psi

Span limit

Maximum span = URL

(can be further adjusted up to \pm URL (TD = 0.5) for differential models, within the range limits)

IT IS RECOMMENDED TO SELECT THE TRANSMITTER SENSOR CODE PROVIDING THE TURNDOWN VALUE AS LOWEST AS POSSIBLE TO OPTIMIZE PERFORMANCE CHARACTERISTICS.

Zero suppression and elevation

Zero and span can be adjusted to any value within the range limits detailed in the table as long as:

– calibrated span \geq minimum span

Damping (feature not available for WirelessHART version)

Selectable time constant : between 0 and 60 s

This is in addition to sensor response time.

Turn on time

Operation within specification in less than 10 s with minimum damping.

Insulation resistance

> 100 M Ω at 500 V DC (terminals to earth)

Specification – operative limits

Pressure limits

Overpressure limits

The differential pressure transmitters, models 266DSH, work without damage within the following pressure limits:

Sensors	Fill fluid	Overpressure limits
Sensor F to S	Silicone oil	0.07 kPa abs, 0.7 mbar abs, 0.5 mmHg and 21 MPa, 210 bar, 3045 psi ⁽¹⁾ ⁽²⁾
Sensor F to Q 266DSH High Static	Silicone oil	0.07 kPa abs, 0.7 mbar abs, 0.5 mmHg and 42 MPa, 420 bar, 6090 psi
Sensor E	Silicone oil	0.07 kPa abs, 0.7 mbar abs, 0.5 mmHg and 16 MPa, 160 bar, 2320 psi ⁽¹⁾
Sensor B	Silicone oil	0.07 kPa abs, 0.7 mbar abs, 0.5 mmHg and 7 MPa, 70 bar, 1015 psi ⁽¹⁾
Sensor A	Silicone oil	0.07 kPa abs, 0.7 mbar abs, 0.5 mmHg and 2 MPa, 20 bar, 290 psi ⁽¹⁾
Sensor F to S	Inert (Galden)	0.135 kPa abs, 1.35 mbar abs, 1 mmHg and 21 MPa, 210 bar, 3045 psi ⁽¹⁾ ⁽²⁾
Sensor E	Inert (Galden)	0.135 kPa abs, 1.35 mbar abs, 1 mmHg and 16 MPa, 160 bar, 2320 psi ⁽¹⁾
Sensor F to S	Inert (Halocarbon)	0.4 kPa abs, 4 mbar abs, 3 mmHg and 21 MPa, 210 bar, 3045 psi ⁽¹⁾ ⁽²⁾
Sensor F to Q 266DSH High Static	Inert (Halocarbon)	0.4 kPa abs, 4 mbar abs, 3 mmHg and 42 MPa, 420 bar, 6090 psi
Sensor E	Inert (Halocarbon)	0.4 kPa abs, 4 mbar abs, 3 mmHg and 16 MPa, 160 bar, 2320 psi ⁽¹⁾

(1) 1 MPa, 10 bar, 145 psi for Kynar-PVDF

(2) 16 MPa, 160 bar, 2320 psi for AISI 316 ss NACE “exposed bolting”

For flange mounted version

Flange	Fill fluid	Overpressure limits
ASME B16.5 Class 150	Silicone oil	0.07 kPa abs, 0.7 mbar abs, 0.5 mmHg and 230 psi
ASME B16.5 Class 300	Silicone oil	0.07 kPa abs, 0.7 mbar abs, 0.5 mmHg and 600 psi
EN 1092-1 PN 16	Silicone oil	0.07 kPa abs, 0.7 mbar abs, 0.5 mmHg and 13.5 bar
EN 1092-1 PN 40	Silicone oil	0.07 kPa abs, 0.7 mbar abs, 0.5 mmHg and 33.8 bar
ASME B16.5 Class 150	Inert (Galden)	0.135 kPa abs, 1.35 mbar abs, 1 mmHg and 230 psi
ASME B16.5 Class 300	Inert (Galden)	0.135 kPa abs, 1.35 mbar abs, 1 mmHg and 600 psi
EN 1092-1 PN 16	Inert (Galden)	0.135 kPa abs, 1.35 mbar abs, 1 mmHg and 13.5 bar
EN 1092-1 PN 40	Inert (Galden)	0.135 kPa abs, 1.35 mbar abs, 1 mmHg and 33.8 bar
ASME B16.5 Class 150	Inert (Halocarbon)	0.4 kPa abs, 4 mbar abs, 3 mmHg and 230 psi
ASME B16.5 Class 300	Inert (Halocarbon)	0.4 kPa abs, 4 mbar abs, 3 mmHg and 600 psi
EN 1092-1 PN 16	Inert (Halocarbon)	0.4 kPa abs, 4 mbar abs, 3 mmHg and 13.5 bar
EN 1092-1 PN 40	Inert (Halocarbon)	0.4 kPa abs, 4 mbar abs, 3 mmHg and 33.8 bar

Static pressure limits

The differential pressure transmitters, models 266DSH work within specifications between the following limits:

Sensors	Static pressure limits
Sensor F to S	1.3 kPa abs, 13 mbar abs, 0.2 psia and 21 MPa, 210 bar, 3045 psi ⁽¹⁾ ⁽²⁾
Sensor F to Q 266DSH High Static	1.3 kPa abs, 13 mbar abs, 0.2 psia and 42 MPa, 420 bar, 6090 psi
Sensor E	1.3 kPa abs, 13 mbar abs, 0.2 psia and 16 MPa, 160 bar, 2320 psi ⁽¹⁾
Sensor B	1.3 kPa abs, 13 mbar abs, 0.2 psia and 7 MPa, 70 bar, 1015 psi ⁽¹⁾
Sensor A	1.3 kPa abs, 13 mbar abs, 0.2 psia and 2 MPa, 20 bar, 290 psi ⁽¹⁾

(1) 1 MPa, 10 bar, 145 psi for Kynar-PVDF

(2) 16 MPa, 160 bar, 2320 psi for AISI 316 ss NACE “exposed bolting”

Flange	Static pressure limits
ASME B16.5 Class 150	1.3 kPa abs, 13 mbar abs, 0.2 psia and 230 psi
ASME B16.5 Class 300	1.3 kPa abs, 13 mbar abs, 0.2 psia and 600 psi
EN 1092-1 PN 16	1.3 kPa abs, 13 mbar abs, 0.2 psia and 13.5 bar
EN 1092-1 PN 40	1.3 kPa abs, 13 mbar abs, 0.2 psia and 33.8 bar

The pressure limit decreases with increasing temperature above 100°F (38°C), according to ASME B16.5 standards or above 50°C according to EN 1092-1 standards.

Proof pressure

The transmitter with threaded process connection can be exposed without leaking to line pressure of up to

- 48 MPa, 480 bar, 6960 psi for standard static version
- 77 MPa, 770 bar, 11165 psi for high static version.
- up to two times the flange rating for the flange mounted version.

Meet ANSI/ISA-S 82.03 hydrostatic test requirements.

Temperature limits °C (°F)

Ambient

is the operating temperature

Models 266DSH	Ambient temperature limits
Silicone oil for sensor F to S	-40 and 85 °C (-40 and 185 °F)
Silicone oil for sensor A to E	-25 and 85 °C (-13 and 185 °F)
Inert (Galden) for sensor F to S	-20 and 85 °C (-4 and 185 °F)
Inert (Galden) for sensor E	-10 and 85 °C (14 and 185 °F)
Inert (Halocarbon) for sensor F to S	-20 and 85 °C (-4 and 185 °F)
Inert (Halocarbon) for sensor E	-10 and 85 °C (14 and 185 °F)

Models 266DSH	Ambient temperature limits
LCD integral display	-40 and 85 °C (-40 and 185 °F)

LCD display may not be clearly readable below -20 °C (-4 °F) or above +70 °C (+158 °F)

IMPORTANT

For Hazardous Atmosphere applications see the temperature range specified on the certificate/approval relevant to the aimed type of protection

Process

Models 266DSH	Process temperature limits
Silicone oil for sensor F to S	-40 and 121 °C (-40 and 250 °F) ⁽¹⁾
Silicone oil for sensor A to E	-25 and 121 °C (-13 and 250 °F) ⁽¹⁾
Inert (Galden) for sensor F to S	-20 and 100 °C (-4 and 212 °F) ⁽²⁾
Inert (Galden) for sensor E	-10 and 100 °C (14 and 212 °F) ⁽²⁾
Inert (Halocarbon) for sensor F to S	-20 and 100 °C (-4 and 212 °F) ⁽²⁾
Inert (Halocarbon) for sensor E	-10 and 100 °C (14 and 212 °F) ⁽²⁾

(1) 100 °C (212 °F) for application below atmospheric pressure

(2) 65 °C (150 °F) for application below atmospheric pressure

Models 266DSH	Process temperature limits
Viton gasket	-20 and 121 °C (-4 and 250 °F)

Storage

Models 266DSH	Storage temperature limits
Storage limits	-50 and 85 °C (-58 and 185 °F)
LCD integral display	-40 and 85 °C (-40 and 185 °F)

Environmental limits

Electromagnetic compatibility (EMC)

Comply with 2014/30/UE to standards EN 61326-1:2013.

For IEC 61508 SIL certified transmitter to EN 61326-3-1:2008.

For transmitter with option "YE" to NAMUR NE 021 (2004).

Surge immunity level (with surge protector): 4 kV (according to IEC 61000-4-5 EN 61000-4-5)

Pressure equipment directive (PED)

Comply with 2014/68/UE to standards

ANSI/ISA 61010-1:2012

Category III Module H for PS ≥ than 20 MPa, 200 bar

Sound Engineering Practice (SEP) for PS < 20 MPa, 200 bar

Humidity

Relative humidity: up to 100 %

Condensing, icing: admissible

Vibration resistance

Accelerations up to 2 g at frequency up to 1000 Hz

(according to IEC 60068-2-6)

Shock resistance

Acceleration: 50 g

Duration: 11 ms

(according to IEC 60068-2-27)

Wet and dust-laden atmospheres

The transmitter is dust and sand tight and protected against immersion effects as defined by IEC 60529 (2001) to IP 67 (IP 68 on request) or by NEMA Type 4X.

IP65 with Harting Han connector.

Aluminium and AISI housings as barrel version also comply to IP 66 as defined by IEC 60529 (2001).

IP66W/IP67W/IP68W as standard for Inmetro certification.

Specification – operative limits

Hazardous atmospheres

(FOR ALL VERSIONS EXCEPT WirelessHART)

With or without integral display

INTRINSIC SAFETY Ex ia:

ATEX Europe (code E1) approval

II 1 G Ex ia IIC T6...T4 Ga and II 1/2 G Ex ia IIC T6...T4 Ga/Gb and

II 1 D Ex ia IIIC T85 °C Da and II 1/2 D Ex ia IIIC T85 °C Da; IP67.

IECEX (code E8) approval

Ex ia IIC T6...T4 Ga/Gb and Ex ia IIIC T85 °C Da; IP67.

NEPSI China (code EY)

Ex ia IIC T4/T5/T6 Ga, Ex ia IIC T4/T5/T6 Ga/Gb,

Ex iaD 20 T85/T100/T135, Ex iaD 20/21 T85/T100/T135.

EXPLOSION PROOF:

ATEX Europe (code E2) approval

II 1/2 G Ex db IIC T6 Ga/Gb Ta=-50 °C to +75 °C and

II 1/2 D Ex tb IIIC T85 °C Db Ta = -50 °C to +75 °C; IP67.

IECEX (code E9) approval

Ex db IIC T6 Ga/Gb Ta=-50 °C to +75 °C and

Ex tb IIIC T85 °C Db Ta = -50 °C to +75 °C; IP67.

NEPSI China (code EZ)

Ex d IIC T6 Gb, Ex tD A21 IP67 T85 °C.

INTRINSIC SAFETY Ex ic:

ATEX Europe (code E3) type examination

II 3 G Ex ic IIC T6...T4 Gc and II 3 D Ex tc IIIC T85 °C Dc; IP67.

IECEX (code ER) type examination

Ex ic IIC T6...T4 Gc and Ex tc IIIC T85 °C Dc; IP67.

NEPSI China (code ES) type examination

Ex ic IIC T4~T6 Gc, Ex nA IIC T4~T6 Gc, Ex tD A22 IP67 T85 °C.

FM Approvals US (code E6) and FM Approvals Canada (code E4):

– Explosionproof (US): Class I, Division 1, Groups A, B, C, D; T5

– Explosionproof (Canada): Class I, Division 1, Groups B, C, D; T5

– Dust-ignitionproof: Class II, Division 1, Groups E, F, G; Class III, Div. 1; T5

– Flameproof (US): Class I, Zone 1 AEx d IIC T4 Gb

– Flameproof (Canada): Class I, Zone 1 Ex d IIC T4 Gb

– Nonincendive: Class I, Division 2, Groups A, B, C, D T6...T4

– Energy limited (US): Class I, Zone 2 AEx nC IIC T6...T4

– Energy limited (Canada): Class I, Zone 2 Ex nC IIC T6...T4

– Intrinsically safe: Class I, II, III, Division 1, Groups A, B, C, D, E, F, G T6...T4

Class I, Zone 0 AEx ia IIC T6...T4 (US)

Class I, Zone 0 Ex ia IIC T6...T4 (Canada)

Type 4X, IP67 for all above markings.

COMBINED FM Approvals US and Canada

– Intrinsically safe (code EA)

COMBINED ATEX, FM and IECEX Approvals (code EN)

Technical Regulations Customs Union EAC (Russia, Kazakhstan, Belarus),

Inmetro (Brazil), Kosha (Korea)

(ONLY FOR WirelessHART VERSION)

With or without integral display

INTRINSIC SAFETY:

ATEX Europe (code E1) approval

II 1 G Ex ia IIC T4 and II 1/2 G Ex ia IIC T4.

IECEX (code E8) approval

Ex ia IIC T4.

FM Approvals US and FM Approvals Canada:

– Intrinsically safe: Class I, Div. 1, Groups A, B, C, D; T4 (code EA)

Class I, Zone 0 AEx ia IIC T4, Gb (FM US)

Class I, Zone 0 Ex ia IIC T4, Gb (FM Canada)

IMPORTANT

REFER TO CERTIFICATES FOR AMBIENT TEMPERATURE RANGES RELATED TO THE DIFFERENT TEMPERATURE CLASSES.

HIGH STATIC VERSION IS NOT IN COMPLIANCE WITH ISA 12.27.01 FOR SEALING REQUIREMENTS, SPECIFICALLY FOR FM APPROVAL (Canada).

Electrical Characteristics and Options

Optional indicators

Integrated digital display

(code LS; only with HART standard functionality)

Wide screen LCD, 128 x 64 pixel,
52.5 x 27.2 mm (2.06 x 1.07 in.) dot matrix.
Two keys for zero/span or without keypad.
User selectable application-specific visualizations.
Display may also indicate static pressure, sensor temperature and diagnostic messages.



Integral display with integral keypad

(code L1; not with HART standard functionality)

Wide screen LCD, 128 x 64 pixel,
52.5 x 27.2 mm (2.06 x 1.07 in.) dot matrix.
Multilanguage. Four keys for configuration and management of device.
Easy setup for quick commissioning.
User selectable application-specific visualizations.
Totalized and instantaneous flow indication.
Display may also indicate static pressure, sensor temperature and diagnostic messages and provides configuration facilities.



Integral display with Through-The-Glass (TTG) activated keypad (code L5; not with HART standard functionality)

As above integral display but equipped with the innovative TTG keypad allowing the activation of the configuration and management menus of the device without the need of removing the transmitter housing cover. TTG keypad is protected against accidental activations.



Optional surge protection

Up to 4kV

- voltage 1.2 μs rise time / 50 μs delay time to half value
- current 8 μs rise time / 20 μs delay time to half value

Process diagnostics (PILD)

Plugged impulse line detection (PILD) generates a warning via communication (HART, PA, FF). The device can be configured to drive the output to “Alarm current” or set a status “BAD”.

HART® digital communication and 4 to 20 mA output – Standard and Advanced functionality

Device type: 1a06_{hex} (listed with HCF)

Power supply

The transmitter operates from 10.5 to 42 V DC with no load and is protected against reverse polarity connection (additional load allows operations over 42 V DC). For Ex ia and other intrinsically safe approval power supply must not exceed 30 V DC. Minimum operating voltage increases to 12.3 V DC with optional surge protector or to 10.8 V DC with optional conformity to NAMUR NE 21 (2004).

Ripple

20 mV max on a 250 Ω load as per HART specifications.

Load limitations

4 to 20 mA and HART total loop resistance :

$$R \text{ (k}\Omega\text{)} = \frac{\text{Supply voltage} - \text{min. operating voltage (V DC)}}{22 \text{ mA}}$$

A minimum of 250 Ω is required for HART communication.

Output signal

Two-wire 4 to 20 mA, user-selectable for linear or square root output, power of $^{3/2}$ or $^{5/2}$, square root for bidirectional flow, 22 points linearization table (i.e. for horizontal or spherical tank level measurement). HART® communication provides digital process variable superimposed on 4 to 20 mA signal, with protocol based on Bell 202 FSK standard.
HART revision 7 is the default HART output.
HART revision 5 is selectable on request.

Output current limits (to NAMUR NE 43 standard)

Overload condition

- Lower limit: 3.8 mA (configurable from 3.8 to 4 mA)
- Upper limit: 20.5 mA (configurable from 20 to 21 mA)

Alarm current

- Lower limit: 3.6 mA (configurable from 3.6 to 4 mA)
- Upper limit: 21 mA (configurable from 20 to 23 mA, limited to 22 mA for HART Safety; apply for electronics release 7.1.15 or later)

Factory setting: high alarm current.

...Specification – electrical characteristics and options

IEC 62591 WirelessHART® output

Device type: 1a06hex (listed with HCF)
 Network ID: ABBhex (2747 decimal)
 Join keys: 57495245_{hex} (1464422981) 4c455353_{hex} (1279611731)
 4649454_{hex} (1179206988) 444b4559_{hex} (1145783641).

Power Supply

1x D-cell size lithium-thionyl chloride battery.
 Battery life: 10 years at 32 sec. update time, 8 years at 16 sec. update time or 5 years at 8 sec. update time.
 (at reference conditions of 25 ± 2 °C ambient temperature, data routed from 3 additional devices, LCD off).

THE BATTERY CAN BE REPLACED IN FIELD, ALSO IN HAZARDOUS CLASSIFIED AREA.

Output signal

IEC 62591 WirelessHART Version 7.5 (IEEE 802.15.4-2006);
 Frequency band: 2.4 GHz DSSS
 Update rate: user selectable from 1 sec. to 60 min.

Integrated adjustable omnidirectional antenna

– Output radio frequency: maximum 10 mW (10 dBm) EIRP
 – Range: up to 300 m. (328 yds.)
 Minimum distance between antenna and person is 0.2 m. (8 in.)

Telecommunications directive

Every wireless measuring device must be certified in accordance with the telecommunications directive, in this case the frequency range. This certification is country-specific.

European directives

Radio Equipment & Telecommunications Terminal Equipment Directive 2014/53/UE to standards EN 60950-1:2013, EN 62311:2008, EN 301 489-1 V1.9.2, EN 301 489-17 V2.2.1, EN 300 328 v1.8.1.
 In Europe, use of the 2400 - 2483.5 MHz frequency band is not harmonized. Country-specific regulations must be observed.

Restrictions for Norway

Operation not permitted within a radius of 20 km around Ny-Alesund in Svalbard. For more information, see www.npt.no Norway Posts and Telecommunications site

Extra-european radio frequency licences

USA to FCC Part 15.247:2009;
 Canada to IC RSS-210 and ICES-003;
 Argentina; United Arab Emirates (UAE); India; Mexico.

PROFIBUS® PA output

Device type

Pressure transmitter compliant to Profiles 3.0.1
 Identification number: 3450 (hex)

Power supply

The transmitter operates from 9 to 32 V DC , polarity independent, with or without surge protector.
 For Ex ia approval power supply must not exceed 17.5 V DC.
 Intrinsic safety installation according to FISCO model.

Current consumption

operating (quiescent): 15 mA
 fault current limiting: 20 mA max.

Output signal

Physical layer in compliance to IEC 1158-2/EN 61158-2 with transmission to Manchester II modulation, at 31.25 kbit/s.

Output interface

PROFIBUS PA communication according to Profibus DP50170 Part 2/DIN 19245 part 1–3.

Output update time

25 ms

Data blocks

3 analog input, 1 physical.

Additional blocks

1 Pressure with calibration transducer block
 1 Advanced Diagnostics transducer block including Plugged Input Line Detection
 1 Local Display transducer block

Transmitter failure mode

On gross transmitter failure condition, detected by self-diagnostics, the output signal can be driven to defined conditions, selectable by the user as safe, last valid or calculated value.
 If electronic failure or short circuit occur the transmitter consumption is electronically limited at a defined value (20 mA approx), for safety of the network.

FOUNDATION Fieldbus™ output

Device type

LINK MASTER DEVICE
 Link Active Scheduler (LAS) capability implemented.
 Manufacturer code: 000320_{hex}
 Device type code: 0007_{hex}

Power supply

The transmitter operates from 9 to 32 V DC, polarity independent, with or without surge protector.
 For Ex ia approval power supply must not exceed 24 V DC (FF-816 certification) or 17.5 V DC (FISCO certification).

Current consumption

operating (quiescent): 15 mA
 fault current limiting: 20 mA max.

Output signal

Physical layer in compliance to IEC 61158-2/EN 61158-2.
 Transmission to Manchester II modulation, at 31.25 kbit/s.

Function blocks/execution period

3 enhanced Analog Input blocks/25 ms max (each)
 1 enhanced PID block/40 ms max.
 1 standard ARithmetic block/25 ms
 1 standard Input Selector block/25 ms
 1 standard Control Selector block/25 ms
 1 standard Signal Characterization block/25 ms
 1 standard Integrator/Totalizer block/25 ms

Additional blocks

1 enhanced Resource block,
 1 custom Pressure with calibration transducer block
 1 custom Advanced Diagnostics transducer block
 including Plugged Input Line Detection
 1 custom Local Display transducer block

Number of link objects

35

Number of VCRs

35

Output interface

FOUNDATION fieldbus digital communication protocol to standard H1, compliant to specification V. 1.7.

Transmitter failure mode

The output signal is “frozen” to the last valid value on gross transmitter failure condition, detected by self-diagnostics which also indicate a BAD conditions. If electronic failure or short circuit occur the transmitter consumption is electronically limited at a defined value (20 mA approx), for safety of the network.

Specification – performance

Stated at reference condition to IEC 60770 ambient temperature of 20 °C (68 °F), relative humidity of 65 %, atmospheric pressure of 1013 hPa (1013 mbar), mounting position with vertical diaphragm and zero based range for transmitter with isolating diaphragms in AISI 316 L ss or Hastelloy and silicone oil fill and HART digital trim values equal to 4 mA and to 20 mA span end points, in linear mode.

Unless otherwise specified, errors are quoted as % of span.

Some performance referring to the Upper Range Limit are affected by the actual turndown (TD) as ratio between Upper Range Limit (URL) and calibrated span.

IT IS RECOMMENDED TO SELECT THE TRANSMITTER SENSOR CODE PROVIDING THE TURNDOWN VALUE AS LOWEST AS POSSIBLE TO OPTIMIZE PERFORMANCE CHARACTERISTICS.

Dynamic performance (according to IEC 61298–1 definition)

Sensors	Total response time
Sensor F to S	≤ 100 ms ⁽¹⁾

Total response time for sensor E ≤ 130 ms, for sensor B ≤ 310 ms ⁽¹⁾

(1) Availability subject to special request for sensors B to H and not applicable for explosionproof and flameproof.

Total response time includes dead time of 30 ms (for all sensors) with time constant @ 63.2 % of total step change. See “Update Rate” for WirelessHART version.

Accuracy rating

% of calibrated span, including combined effects of terminal based linearity, hysteresis and repeatability.

For fieldbus versions SPAN refer to analog input function block outscale range

Model	Sensor	for TD	
266DSH standard static and for gauge application	F to P	from 1:1 to 10:1	± 0.06 %
	F to P	from 10:1 to 100:1	± (0.006 x TD) %
	E, Q, S	from 1:1 to 10:1	± 0.075 %
	Q and S	from 10:1 to 100:1	± (0.0075 x TD) %
	E	from 10:1 to 30:1	± (0.0075 x TD) %
	B	from 1:1 to 10:1	± 0.10 %
266DSH (option D2)	B	from 10:1 to 20:1	± (0.01 x TD) %
	A	from 1:1 to 4:1	± 0.10 %
	A	from 4:1 to 20:1	± (0.025 x TD) %
	F to Q	from 1:1 to 5:1	± 0.04 %
266DSH high static	F to P	from 5:1 to 100:1	± (0.0105 + 0.0059 x TD) %
	Q	from 5:1 to 100:1	± (0.003 + 0.0074 x TD) %
266DSH high static	F to Q	from 1:1 to 10:1	± 0.075 %
	F to Q	from 10:1 to 100:1	± (0.0075 x TD) %

Ambient temperature

per 20K change between the limits of –40 °C to +85 °C (per 36 °F change between the limits of –40 to +185 °F):

Model	Sensor	for TD up to	
266DSH	F to Q	10:1	± (0.03 % URL + 0.045 % span)
	E and S	10:1	± (0.04 % URL + 0.065 % span)
	B	10:1	± (0.06 % URL + 0.10 % span)
	A	4:1	± (0.10 % URL + 0.10 % span)

for an ambient temperature change from –10 °C to +60 °C (+14 to +140 °F):

Model	Sensor	for TD up to	
266DSH	F to Q	10:1	± (0.055 % URL + 0.08 % span)
	E and S	10:1	± (0.075 % URL + 0.11 % span)
	B	10:1	± (0.11 % URL + 0.18 % span)
	A	4:1	± (0.18 % URL + 0.18 % span)

per 10K change between the limits of –40 °C to –10 °C or +60 °C to +85 °C (per 18 °F change between the limits of –40 to +14 °F or +140 °C to +185 °F):

Model	Sensor	for TD up to	
266DSH	F to Q	10:1	± (0.03 % URL + 0.04 % span)
	E and S	10:1	± (0.04 % URL + 0.055 % span)
	B	10:1	± (0.055 % URL + 0.09 % span)
	A	4:1	± (0.09 % URL + 0.09 % span)

Static pressure

(zero errors can be calibrated out at line pressure)

per 0.5 MPa, 5 bar or 72.5 psi (sensor A)

per 2 MPa, 20 bar or 290 psi (sensor B)

per 3.5 MPa, 35 bar or 500 psi (sensor E)

per 7 MPa, 70 bar or 1015 psi (sensor F to S)

Model 266DSH standard static

- zero error: ±0.05 % of URL for sensor F to S
±0.08 % of URL for sensor A, B and E
- span error: ±0.08 % of reading.

Model 266DSH high static

- zero error: ±0.08 % of URL for sensor F to Q
- span error: ±0.20 % of reading.

Model 266DSH flange mounted

per 2 MPa, 20 bar or 290 psi

- zero error: ±0.05 % of URL for sensor F to P
±0.08 % of URL for sensor E

span error: ±0.08 % of reading.

Supply voltage

Within voltage/load specified limits the total effect is less than 0.005 % of URL per volt.

Load

Within load/voltage specified limits the total effect is negligible.

Electromagnetic field

Meets all the requirements of EN 61326 for surge immunity level (of NAMUR NE 21 on request).

Common mode interference

No effect from 100Vrms @ 50Hz, or 50 V DC

Mounting position

No effect for rotation on diaphragm plane. A tilt up to 90° from vertical causes a zero shifts up to 0.5 kPa, 5 mbar or 2 inH2O, which can be corrected with zero adjustment. No span effect.

Stability

±0.15 % of URL over a ten years period
 (±0.25 % of URL over a ten years period for sensor A or B)
 0.15 % of URL over a five years period for 266DSH high static.

Maximum total performance

For temperature change of 28 °C (50 °F), static pressure change of 5,1 MPa, 51 bar, 740 psi, for model 266DSH with accuracy option code D2 (± 0.04 %)

Sensor	Span	Maximum total performance
F	35 kPa, 350 mbar, 140 inH2O	≤± 0.125 % of calibrated span
H	150 kPa, 1,5 bar, 600 inH2O	
M	550 kPa, 5,5 bar, 80 psi	

$$E_{\text{Mperf}} = \sqrt{(E_{\Delta Tz} + E_{\Delta Ts})^2 + E_{\Delta Ps}^2 + E_{\text{lin}}^2}$$

E_{Mperf} = Maximum total performance

$E_{\Delta Tz}$ = Effect of the ambient temperature on zero

$E_{\Delta Ts}$ = Effect of the ambient temperature on span

$E_{\Delta Ps}$ = Effect of the static pressure on span

E_{lin} = Accuracy rating (for terminal-based linearity 0.04 %)

Total performance

similar to DIN 16086

Temperature change in the range from -10 to 60 °C (14 to 140 °F), static pressure change (266DSH) 10 MPa, 100 bar, 1450 psi

Model	Sensor	TD	Total performance
266DSH std. static, D2 option	F to Q	1:1	≤± 0.16 % of calibrated span

$$E_{\text{perf}} = \sqrt{(E_{\Delta Tz} + E_{\Delta Ts})^2 + E_{\Delta Ps}^2 + E_{\text{lin}}^2}$$

E_{perf} = Total Performance

$E_{\Delta Tz}$ = Effect of the ambient temperature on zero

$E_{\Delta Ts}$ = Effect of the ambient temperature on span

$E_{\Delta Ps}$ = Effect of the static pressure on span (266DSH only)

E_{lin} = Accuracy rating (for terminal-based linearity 0.04 % or 0.075% as per model/sensor accuracy)

Maximum total performance and Total performance includes the measuring errors of

- non-linearity including hysteresis and non-reproducibility,
- thermal change of the ambient temperature as regards the zero signal and the calibrated span,
- effect of static pressure change on the calibrated span,
- with transmitter re-zeroed at line pressure.

Specification – physical

(Refer to ordering information sheets for variant availability related to specific model or versions code)

Materials

Process isolating diaphragms (*)

AISI 316 L ss; AISI 316 L ss gold plated; Monel 400[®]; Tantalum; Hastelloy[®] C-276; Hastelloy[®] C-276 on AISI 316L ss gasket seat.

Process flanges, adapters, plugs and drain/vent valves (*)

AISI 316 L ss ⁽¹⁾; Hastelloy[®] C-276 ⁽²⁾; Monel 400[®] ⁽³⁾; Kynar[®] (PVDF insert in AISI 316 ss flange).
AISI 316 L ss with flushing connections for high side of flange mounted version.

Sensor fill fluid

Silicone oil; Inert fill (Halocarbon[®] 4.2 or Galden[®]).

Mounting bracket (**)

Zinc plated carbon steel with chrome passivation; AISI 316 ss; AISI 316 L ss.

Gaskets (*)

Viton[®]; PTFE.

Sensor housing

AISI 316 L ss.

Bolts and nuts

AISI 316 ss bolts Class A4–80 and nuts Class A4–70 per ISO 3506;
AISI 316 ss bolts and nuts Class A4–50 per ISO 3506, in compliance with NACE MR0175 Class II (std. static only).
Plated alloy steel bolts per ASTM-A-193-77a grade B7M and nuts per ASTM A194/A 194 M-90 grade 2HM, in compliance with NACE MR0175 Class II.
Stainless steel per ASTM-A-453 grade 660D, in compliance with NACE MR0175 Class II (high static only).

Electronic housing and covers

Aluminium alloy (copper content $\leq 0.3\%$) with baked epoxy finish (colour RAL9002); AISI 316 L ss.

Covers O-ring

Buna N.

Local adjustments (zero, span and write protect)

For Standard HART version:

- Internal for zero and span (on connection board)
- External non-intrusive for zero, span and write protect in glass filled polyphenylene oxyde, removable (code R1).

For all other versions:

- External non-intrusive for zero, span and write protect in glass filled polyphenylene oxyde, removable.

Plates

Transmitter nameplate: AISI 316 ss screwed to the electronics housing.

Certification plate and optional tag/calibration plate : self-adhesive attached to the electronics housing or AISI 316 ss fastened to the electronics housing with rivets or screws.

Optional wired-on customer data plate: AISI 316 ss.

Laser printing on metal or thermal printing on self-adhesive.

For AISI 316 L ss housing it is mandatory to select option I2 or I3 for plates in AISI 316 ss.

Calibration

Standard: at maximum span, zero based range, ambient temperature and pressure;

Optional: at specified range and ambient conditions.

(*) Wetted parts of the transmitter.

(**) U-bolt material: high-strength alloy steel or AISI 316 L ss;
bolts/nuts material: high-strength alloy steel or AISI 316 ss.

⁽¹⁾ Supplied as AISI 316 L or as ASTM A351 Grade CF-3M

⁽²⁾ Supplied as Hastelloy C-276 or as ASTM A494 alloy CW-12MW

⁽³⁾ Supplied as Monel 400 or as ASTM A494 Grade M-35-1

Optional extras

Mounting brackets (code Bx)

For vertical and horizontal 60mm. (2in) pipes or wall mounting. (EXCEPT U-BOLT ASSEMBLY WHICH IS NOT SUPPLIED FOR WALL MOUNTING, PARTS ARE THE SAME FOR PIPE AND WALL BRACKET OPTIONS, AS PER RELEVANT MATERIALS).

Display (code Lx)

4-position (at 90°) user orientable, except "LS".

Optional plates (code Ix)

Code I1: AISI 316 ss wired-on plate with laser printed customized data (4 lines of 32 characters with 4 mm/0.16 in. height).

Code I2: AISI 316 ss plate with laser printed tag (up to 31 characters) and calibration details (up to 31 characters: lower and upper range values and engineering unit) fixed onto transmitter housing.

Code I3: complete set of AISI 316 ss plates (see I1 and I2).

Surge protection (code S2)

Cleaning procedure for oxygen service (code P1)

Test Certificates (test, design, calibration, material traceability) (codes Cx and Hx)

Tag and manual language (codes Tx and Mx)

Manifold mounting (code A1)

Factory mounting and pressure test of ABB M26 manifolds.

Process connections

on flanges: 1/4 in. – 18 NPT on process axis

on adapters: 1/2 in. – 14 NPT on process axis

centre distance (266DSH): 54 mm. (2.13 in.) on flange; 51, 54 or 57 mm. (2.01, 2.13 or 2.24 in.) as per adapters fittings

fixing threads: 7/16 in. – 20 UNF at 41.3 mm centre distance

High pressure side of flange mounted version (*):

2 in. or 3 in., ASME Class 150 or Class 300 RF;

DN 50 or DN 80, PN 16 or PN 40 to EN 1092-1 Type B1

Electrical connections

Two 1/2 in. – 14 NPT or M20x1.5 threaded conduit entries, direct on housing. Only M20x1.5 for WirelessHART with one port used for antenna.

One certified stainless steel plug (supplied loose with thread according to housing entries) available as option.

Terminal block

HART version: three terminals for signal/external meter wiring up to 2.5 mm² (14 AWG), also connection points for test and communication purposes.

WirelessHART version: connection points for test and communication purposes; additional fast connection for external harvesting unit.

Fieldbus versions: two terminals for signal wiring (bus connection) up to 2.5 mm² (14 AWG)

Grounding

Internal and external 6 mm² (10 AWG) ground termination points are provided.

Mounting position

Transmitter can be mounted in any position.

Electronics housing may be rotated to any position. A positive stop prevents over travel.

Mass (without options)

4 kg approx (8.8 lb) for standard static and gauge versions;

4.35 kg approx (9.6 lb) for high static version;

7 to 11 kg approx (16 to 24 lb) for flange mounted version; add 1.5 kg (3.3 lb) for AISI housing.

Add 650 g (1.5 lb) for packing.

Packing

Carton 27 x 24 x 20 cm approx (11 x 10 x 8 in.);

Carton 35 x 33 x 35 cm approx (14 x 13 x 14 in) for flange mounted version.

(*) Bolts and nuts, gasket and mating flange supplied by customer.

Specification – configuration

Transmitter with HART communication and 4 to 20 mA

Standard configuration

Transmitters are factory calibrated to customer's specified range. Calibrated range and tag number are stamped on the tag plate. If a calibration range and tag data are not specified, the transmitter will be supplied with the plate left blank and configured as follows:

Engineering Unit	kPa
4 mA	Zero
20 mA	Upper Range Limit (URL)
Output	Linear
Damping	1 s
Transmitter failure mode	Upscale
Software tag (8 char. max)	Blank
Optional LCD display	PV in kPa; output in mA and in percentage on bargraph

Any or all the above configurable parameters, including Lower range-value and Upper range-value which must be the same unit of measure, can be easily changed using the HART hand-held communicator or by a PC running the configuration software with DTM for 266 models. The transmitter database is customized with specified flange type and material, O-ring and drain/vent materials and meter code option.

Custom configuration (option N6)

The following data may be specified in addition to the standard configuration parameters:

Descriptor	16 alphanumeric characters
Message	32 alphanumeric characters
Date	Day, month, year

For HART protocol available engineering units of pressure measure are :

Pa, kPa, MPa

inH₂O@4 °C, mmH₂O@4 °C, psi

inH₂O@68 °F, ftH₂O@68 °F, mmH₂O@68 °F

inHg, mmHg, Torr

g/cm², kg/cm², atm

mbar, bar

These and others are available for PROFIBUS and FOUNDATION Fieldbus.

Transmitter with WirelessHART communication

Standard configuration

Transmitters are factory calibrated to customer's specified range. Calibrated range and tag number are stamped on the tag plate. If a calibration range and tag data are not specified, the transmitter will be supplied with the plate left blank and configured as follows:

Engineering Unit	kPa
Output scale 0 %	Lower Range Limit (LRL)
Output scale 100 %	Upper Range Limit (URL)
Output	Linear
Update time	16 s
Software tag (8 char. max)	Blank
Optional LCD display	PV in kPa; output in percentage on bargraph

Any or all the above configurable parameters, including Lower range-value and Upper range-value which must be the same unit of measure, can be easily changed using the HART hand-held communicator or by a PC running the configuration software with DTM for 266 models. The transmitter database is customized with specified flange type and material, O-ring and drain/vent materials and meter code option.

Custom configuration (option N6)

The following data may be specified in addition to the standard configuration parameters:

Descriptor	16 alphanumeric characters
Message	32 alphanumeric characters
Date	Day, month, year

Transmitter with PROFIBUS PA communication

Standard configuration

Transmitters are factory calibrated to customer's specified range. Calibrated range and tag number are stamped on the tag plate. If a calibration range and tag data are not specified, the transmitter will be supplied with the plate left blank and configured as follows:

Measure Profile	Pressure
Engineering Unit	kPa
Output scale 0 %	Lower Range Limit (LRL)
Output scale 100 %	Upper Range Limit (URL)
Output	Linear
Hi-Hi Limit	Upper Range Limit (URL)
Hi Limit	Upper Range Limit (URL)
Low Limit	Lower Range Limit (LRL)
Low-Low Limit	Lower Range Limit (LRL)
Limits hysteresis	0.5 % of output scale
PV filter	0 s
Address (set by local key)	126
Tag	32 alphanumeric characters
Optional LCD display	PV in kPa; output in percentage on bargraph

Any or all the above configurable parameters, including the range values which must be the same unit of measure, can be easily changed by a PC running the configuration software with DTM for 266 models. The transmitter database is customized with specified flange type and material, O-ring and drain/vent materials and meter code option.

Custom configuration (option N6)

The following data may be specified in addition to the standard configuration parameters:

Descriptor	32 alphanumeric characters
Message	32 alphanumeric characters
Date	Day, month, year

Transmitter with FOUNDATION Fieldbus communication

Standard configuration

Transmitters are factory calibrated to customer's specified range. Calibrated range and tag number are stamped on the tag plate. If a calibration range and tag data are not specified, the transmitter will be supplied with the plate left blank and the analog input function block FB1 is configured as follows:

Measure Profile	Pressure
Engineering Unit	kPa
Output scale 0 %	Lower Range Limit (LRL)
Output scale 100 %	Upper Range Limit (URL)
Output	Linear
Hi-Hi Limit	Upper Range Limit (URL)
Hi Limit :	Upper Range Limit (URL)
Low Limit	Lower Range Limit (LRL)
Low Limit	Lower Range Limit (LRL)
Limits hysteresis	0.5 % of output scale
PV filter time	0 s
Tag	32 alphanumeric characters
Optional LCD display	PV in kPa; output in percentage on bargraph

The analog input function block FB2 and FB3 are configured respectively for the sensor temperature measured in °C and for the static pressure measured in MPa.

Any or all the above configurable parameters, including the range values, can be changed using any host compliant to FOUNDATION fieldbus. The transmitter database is customized with specified flange type and material, O-ring and drain/vent materials and meter code option.

Custom configuration (option N6)

The following data may be specified in addition to the standard configuration parameters:

Descriptor	32 alphanumeric characters
Message	32 alphanumeric characters
Date	Day, month, year

Dimensions

(not for construction unless certified) – dimensions in mm. (in.)

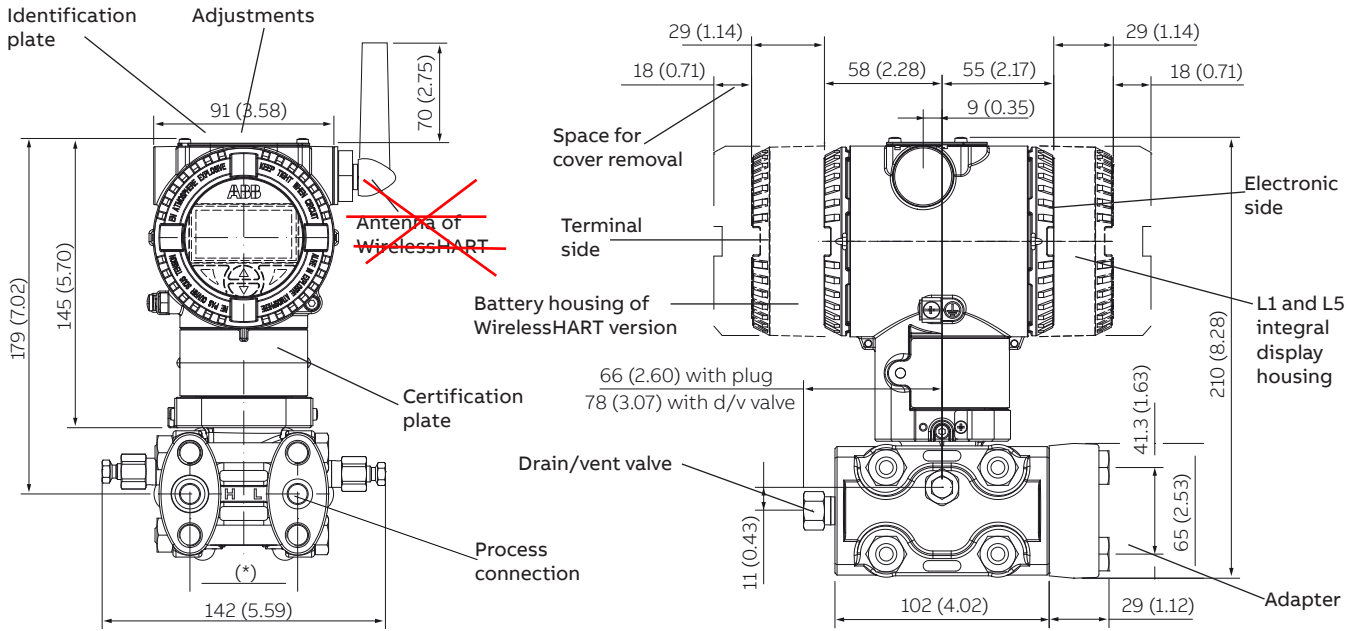

(*) 54 (2.13) mm (in) on 1/4 – 18 NPT process flange; 51 (2.01), 54 (2.13) or 57 (2.24) mm (in) according to 1/2 – 14 NPT adapters fitting 54 (2.13) mm (in) with negative side provided with a removable filter for gauge measurement (version 266DSHxP)

Figure 1 Standard static transmitter with barrel housing - horizontal flanges

NOTE

Process connection, gasket groove and gaskets are in accordance with IEC 61518.

Bolting threads for fixing adapter or other devices (i.e. manifold etc.) on process flange is 7/16 – 20 UNF.

Negative side of gauge measurement version 266DSHxP is provided with a removable filter, granting protection to the atmospheric pressure reference.

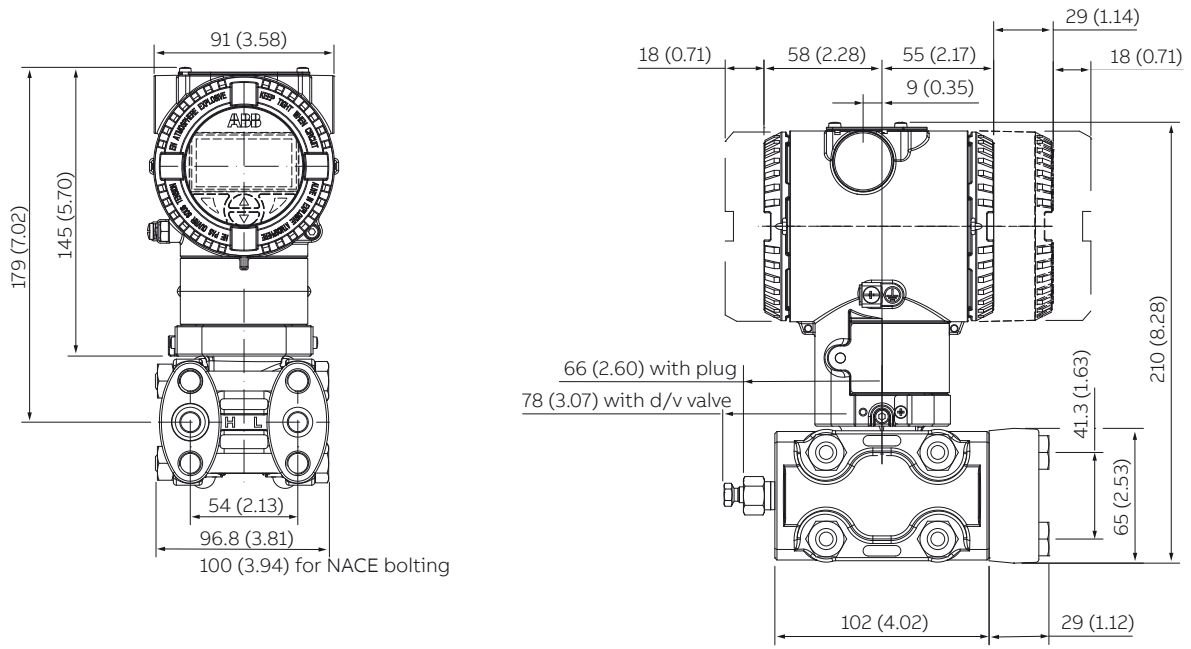

Figure 2 High static transmitter with barrel housing - horizontal flanges

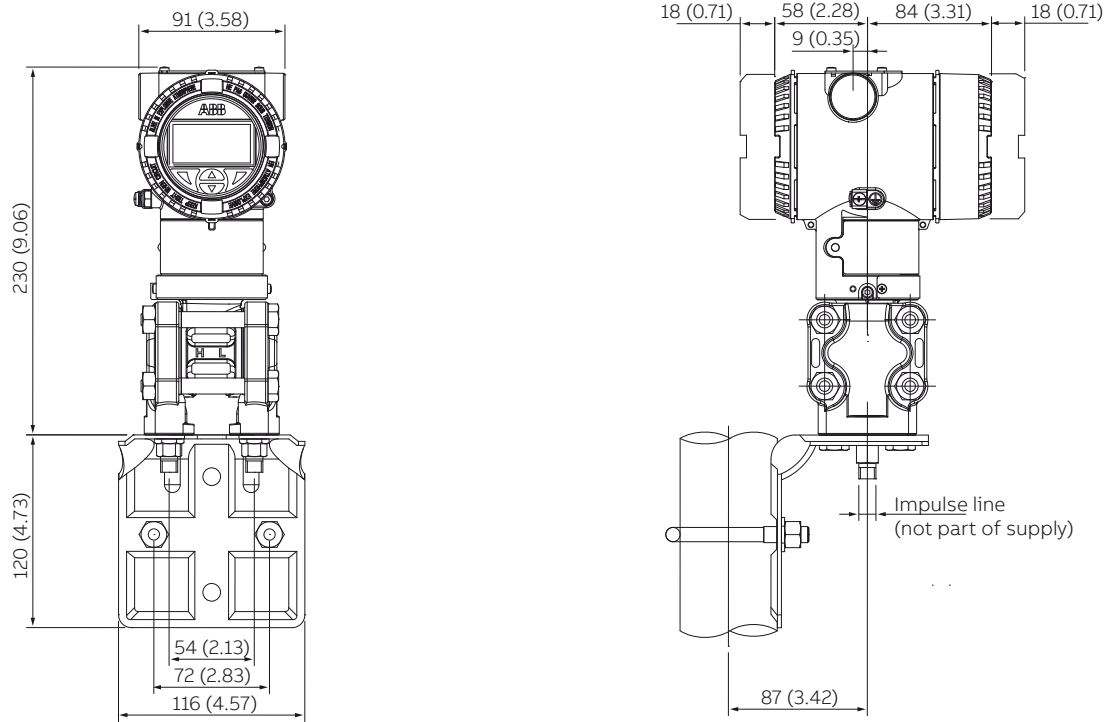

Figure 3 Standard static transmitter with barrel housing - vertical flanges

...Dimensions

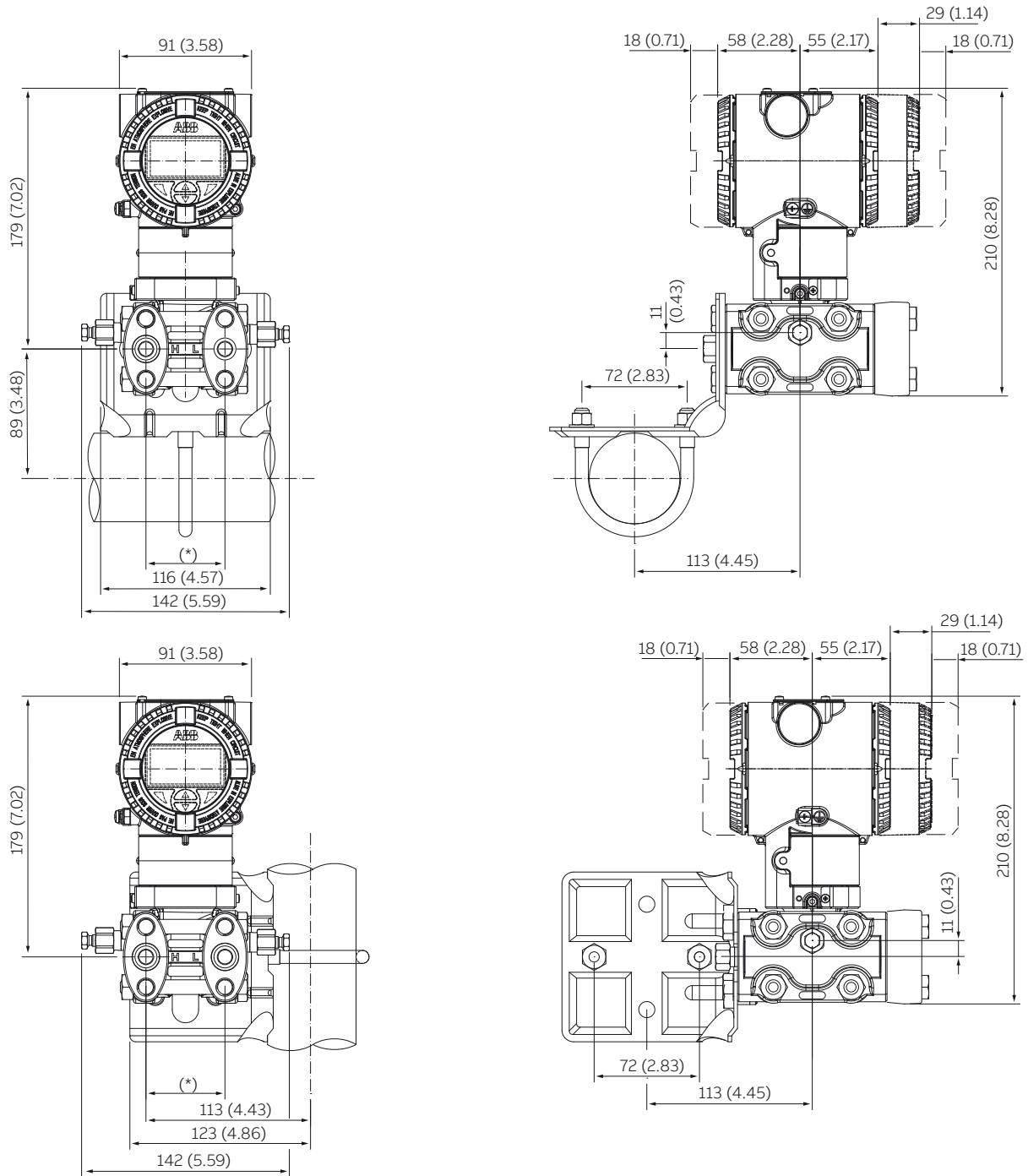

Figure 4 Transmitter on bracket for vertical or horizontal 60 mm. (2 in.) pipe mounting

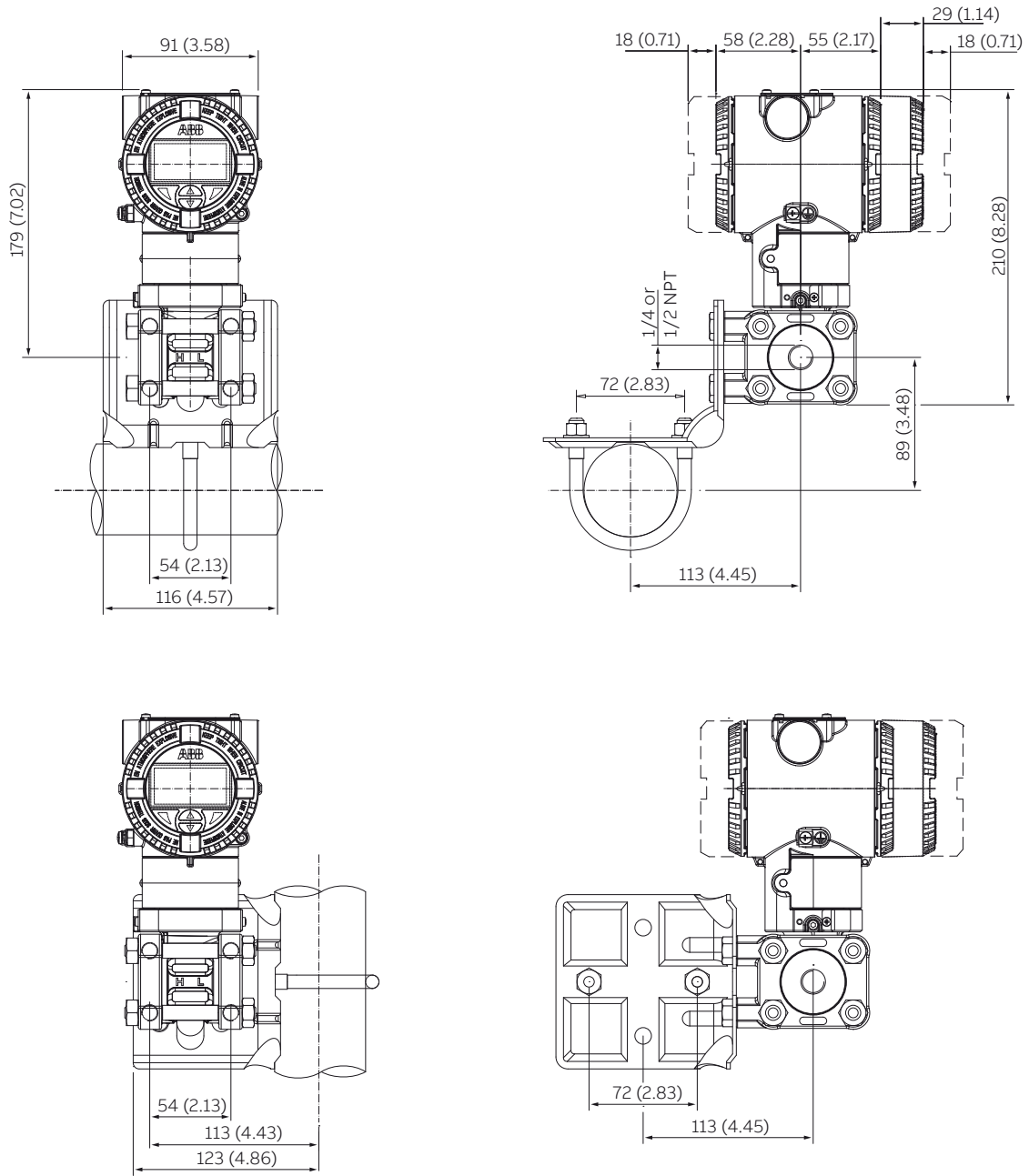

Figure 5 Transmitter with Kynar flanges on bracket for vertical or horizontal 60 mm. (2 in.) pipe mounting

...Dimensions

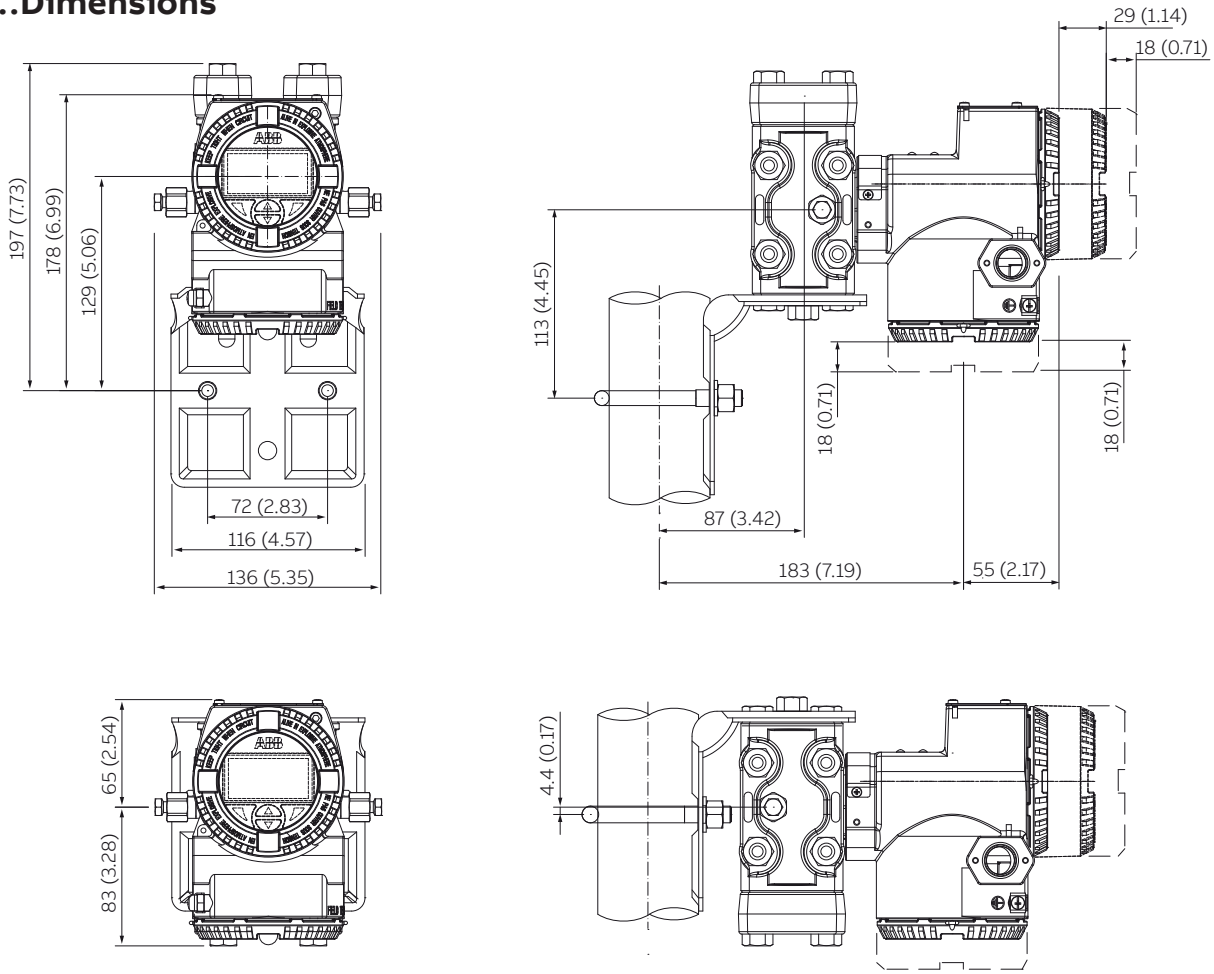

Figure 6 Transmitter with DIN aluminium housing - horizontal flanges on bracket for vertical or horizontal 60 mm. (2 in.) pipe mounting

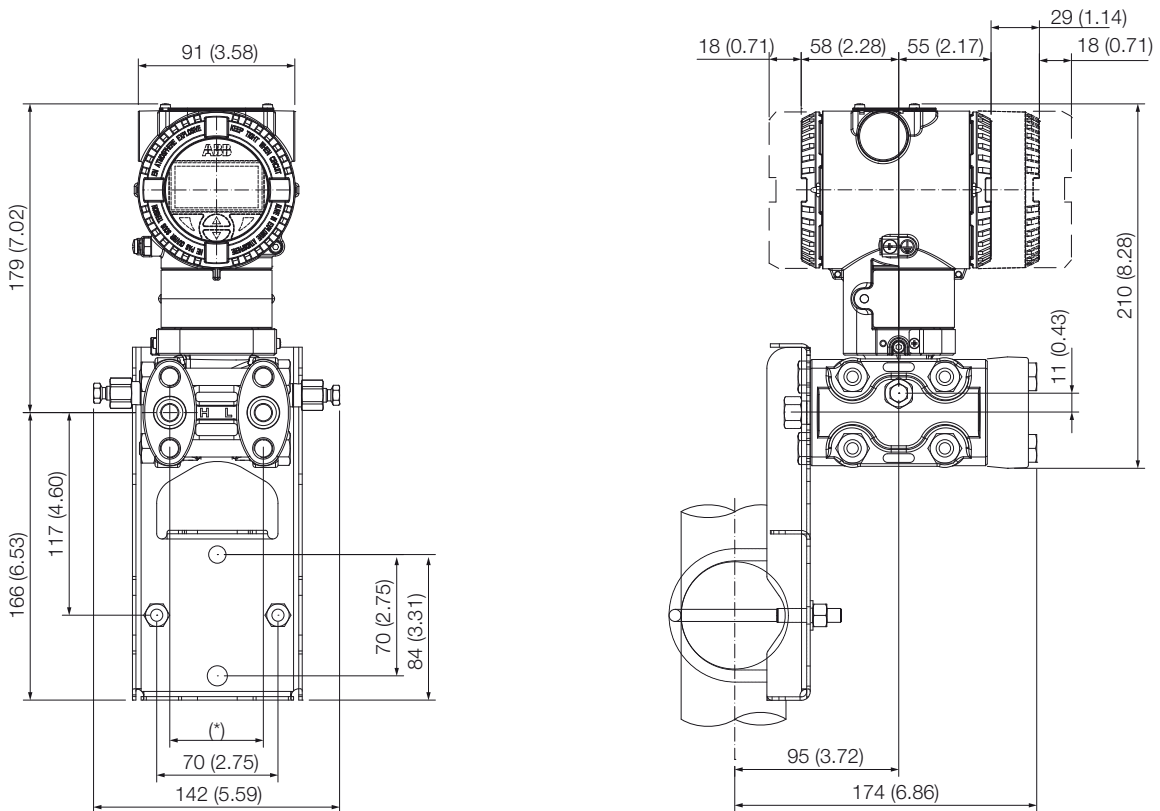

Figure 7 Transmitter with horizontal flanges on flat bracket for vertical or horizontal 60 mm. (2 in.) pipe mounting

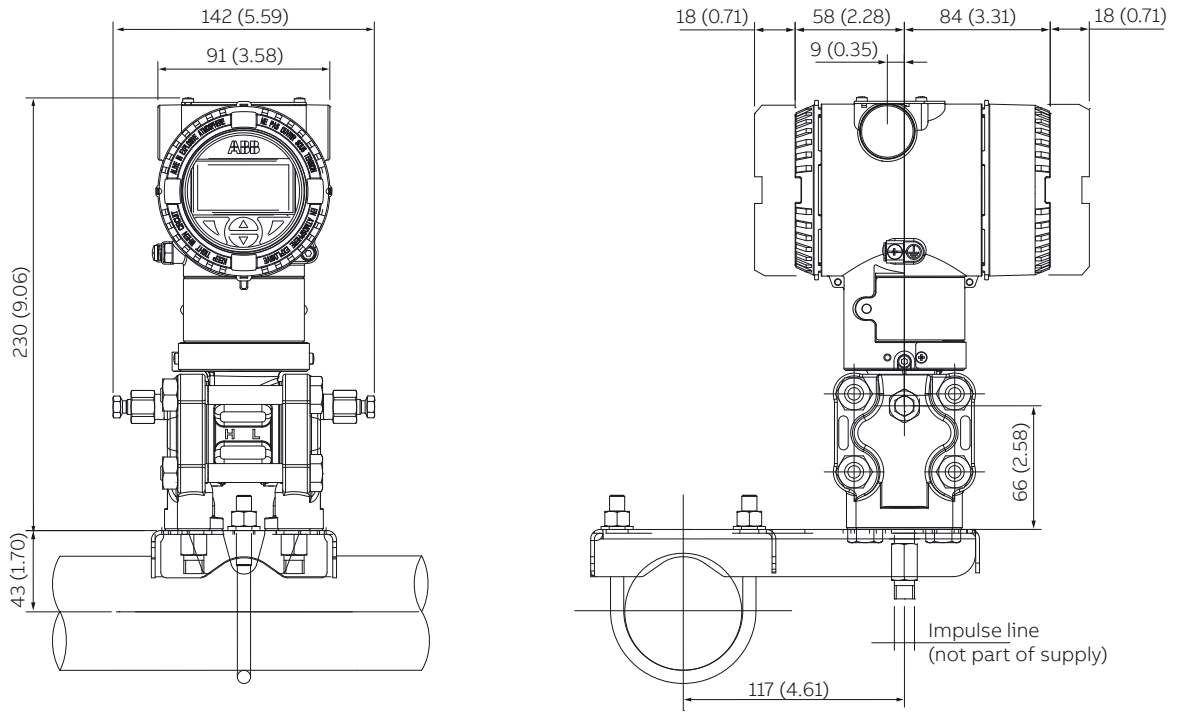

Figure 8 Transmitter with vertical flanges on bracket for vertical or horizontal 60 mm. (2 in.) pipe mounting

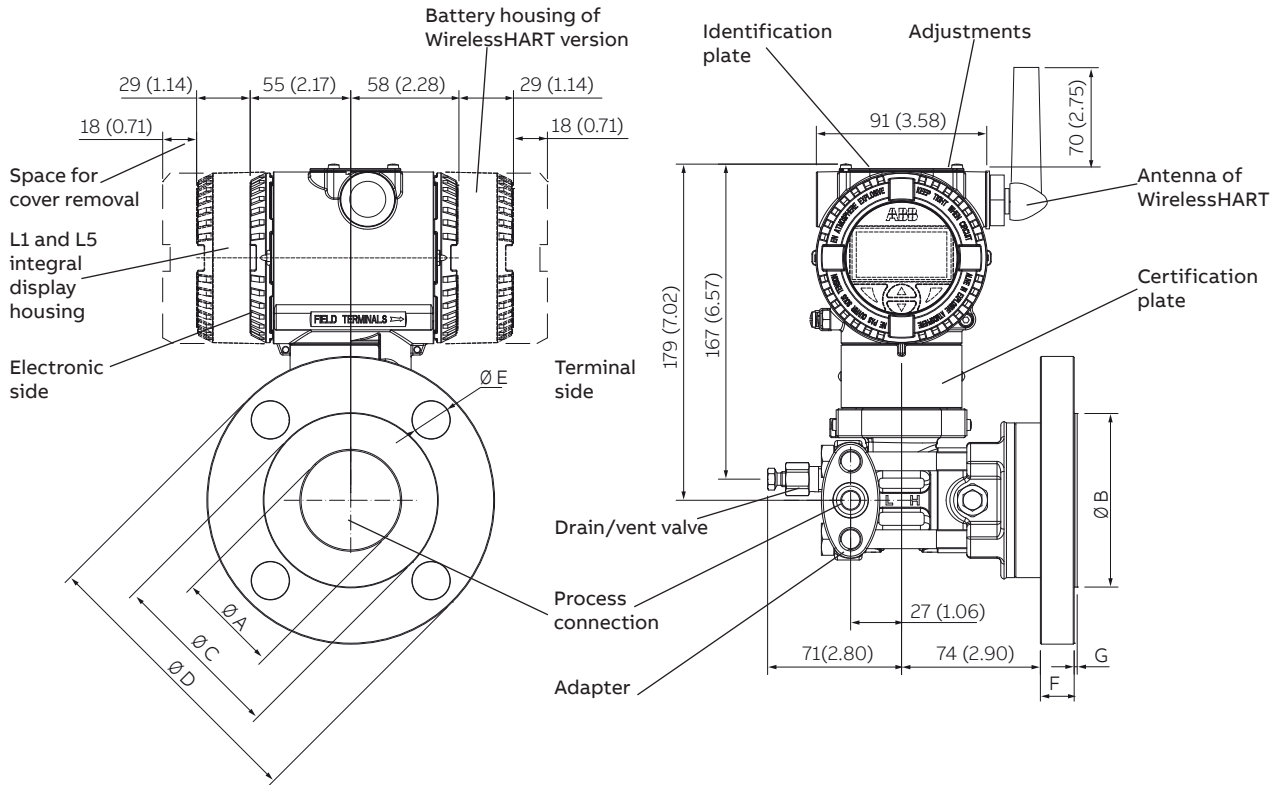
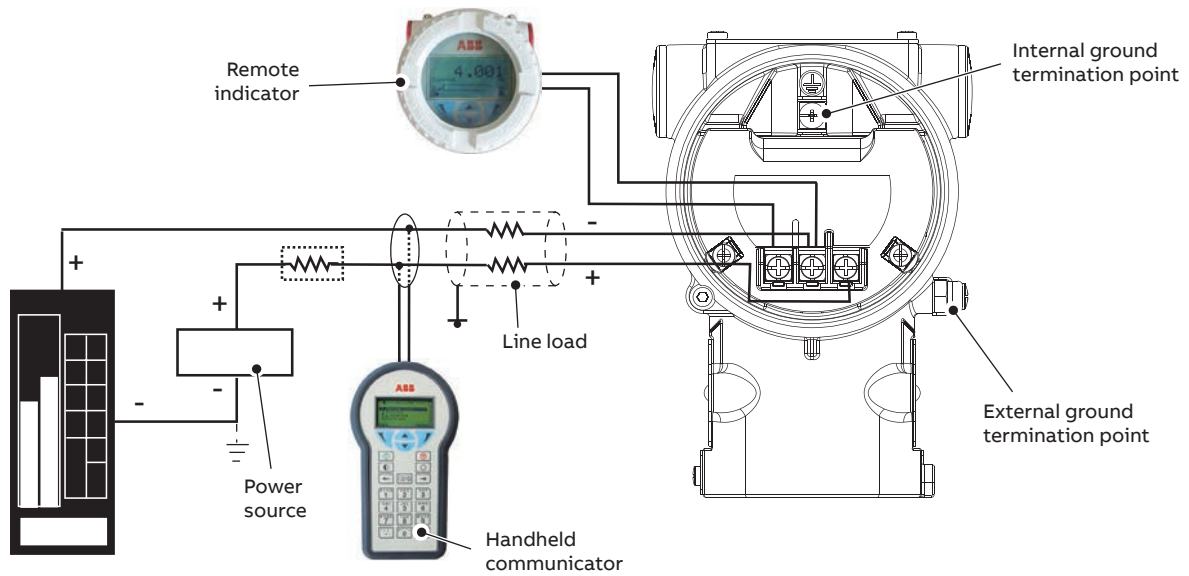

Figure 9 Transmitter with barrel housing - flange mounted version

Electrical connections



HART hand-held communicator may be connected at any wiring termination point in the loop, providing the minimum resistance is 250 ohm. If this is less than 250 ohm, additional resistance should be added to allow communications. Maximum voltage drop on external remote indicator is 0.7 V DC.

Figure 11 HART Version

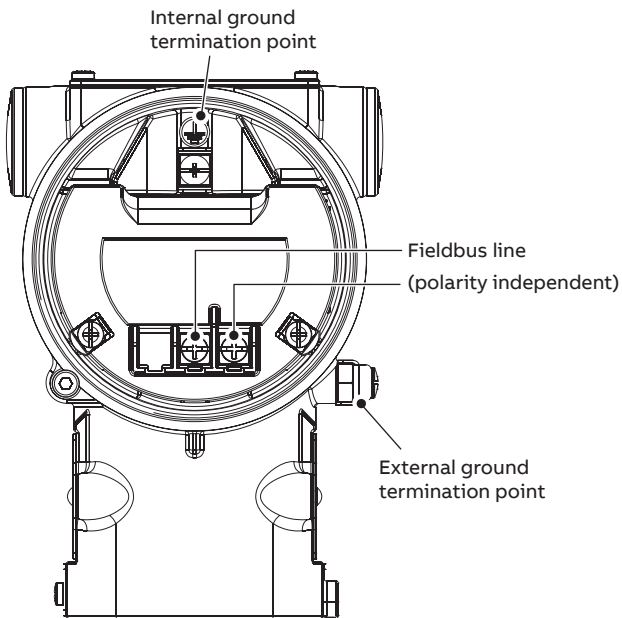

Figure 12 FIELDBUS Versions

...Electrical connections

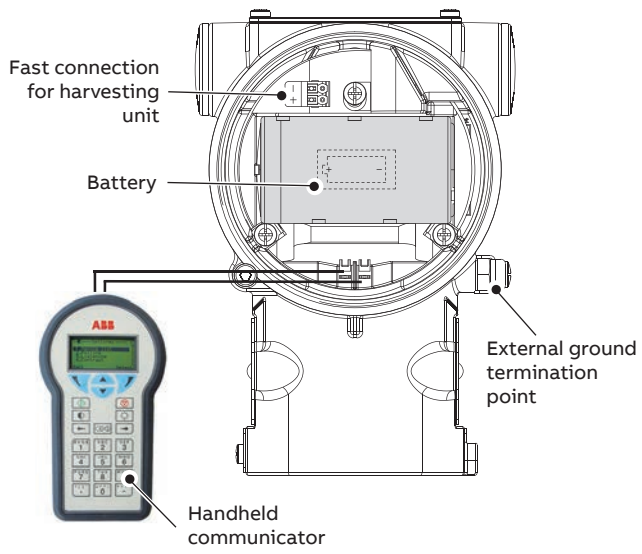

Figure 13 WirelessHART version

Ordering Information

Basic ordering information for model 266DSH Differential Pressure Transmitter

Select one character or set of characters from each category and specify complete catalog number.

Refer to additional ordering information and specify one or more codes for each transmitter if additional options are required.

BASE MODEL - 1st to 6th characters				2	6	D	S	H	X	X	X	X	X	X	X
Differential Pressure Transmitter – BASE ACCURACY 0.06 %															
SENSOR - Span limits - 7th character															
0.05 and 1 kPa	0.5 and 10 mbar	0.2 and 4 inH2O	(Notes 17, 30) "Vx" OPTION IS REQUIRED						A						
0.2 and 4 kPa	2 and 40 mbar	0.8 and 16 inH2O	(Notes 17, 30)						B						
0.54 and 16 kPa	5.4 and 160 mbar	2.16 and 64 inH2O	(Note 17)						E						
0.4 and 40 kPa	4 and 400 mbar	1.6 and 160 inH2O							F						
1.6 and 160 kPa	16 and 1600 mbar	6.4 and 642 inH2O							H						
6 and 600 kPa	0.06 and 6 bar	0.87 and 87 psi							M						
24 and 2400 kPa	0.24 and 24 bar	3.5 and 348 psi							P						
80 and 8000 kPa	0.8 and 80 bar	11.6 and 1160 psi							Q						
160 and 16000 kPa	1.6 and 160 bar	23.2 and 2320 psi	(Note 17)						S						
Application - 8th character															
Differential measurement at standard static pressure															
Differential measurement at high static pressure (REMARK)				(Note 30)											
Gauge measurement															
Diaphragm material / Fill fluid (wetted parts) - 9th character															
AISI 316 L ss		Silicone oil	(Note 2)						NACE						S
Hastelloy® C-276 (on AISI seat)		Silicone oil	(Note 16, 17, 30)						NACE						H
Hastelloy® C-276		Silicone oil	(Note 30)						NACE						K
Monel 400®		Silicone oil	(Notes 2, 17, 30)						NACE						M
AISI 316 L ss gold plated		Silicone oil	(Notes 2, 17, 30)						NACE						8
Tantalum		Silicone oil	(Notes 2, 17, 30)						NACE						T
AISI 316 L ss		Inert fluid - Galden	(Notes 1, 2, 17, 30)						NACE						A
Hastelloy® C-276		Inert fluid - Galden	(Notes 1, 2, 17, 30)						NACE						F
Monel 400®		Inert fluid - Galden	(Notes 1, 2, 17, 30)						NACE						C
AISI 316 L ss gold plated		Inert fluid - Galden	(Notes 1, 2, 17, 30)						NACE						9
Tantalum		Inert fluid - Galden	(Notes 1, 2, 17, 30)						NACE						D
AISI 316 L ss		Inert fluid - Halocarbon	(Notes 1, 2, 30)						NACE						L
Hastelloy® C-276		Inert fluid - Halocarbon	(Notes 1, 2, 30)						NACE						P
Monel 400®		Inert fluid - Halocarbon	(Notes 1, 2, 17, 30)						NACE						4
AISI 316 L ss gold plated		Inert fluid - Halocarbon	(Notes 1, 2, 17, 30)						NACE						I
Tantalum		Inert fluid - Halocarbon	(Notes 1, 2, 17, 30)						NACE						5

continued see next page

REMARK

HIGH STATIC VERSION IS NOT IN COMPLIANCE WITH ISA 12.27.01 FOR SEALING REQUIREMENTS, SPECIFICALLY FOR FM APPROVAL (Canada).

...Ordering information

...Basic ordering information for model 266DSH Differential Pressure Transmitter

Basic ORDERING INFORMATION model 266DSH Differential Pressure Transmitter						2	6	D	S	H	X	X	X	X
Process flanges/adapters material and connection (wetted parts) - 10th character														
→	AISI 316 L ss (Horizontal connection)	1/4 in. – 18 NPT-f direct			NACE						A			
	AISI 316 L ss (Horizontal connection)	1/2 in. – 14 NPT-f through adapter			NACE						B			
	Hastelloy® C-276 (Horizontal connection)	1/4 in. – 18 NPT-f direct	(Notes 3, 30)		NACE						D			
	Hastelloy® C-276 (Horizontal connection)	1/2 in. – 14 NPT-f through adapter	(Notes 3, 30)		NACE						E			
	Monel 400® (Horizontal connection)	1/4 in. – 18 NPT-f direct	(Notes 3, 4, 17, 30)		NACE						G			
	Monel 400® (Horizontal connection)	1/2 in. – 14 NPT-f through adapter	(Notes 3, 4, 17, 30)		NACE						H			
	AISI 316 L ss (Vertical connection)	1/4 in. – 18 NPT-f direct	(Note 17)		NACE						Q			
	AISI 316 L ss (Vertical connection)	1/2 in. – 14 NPT-f through adapter	(Note 17)		NACE						T			
	Hastelloy® C-276 (Vertical connection)	1/4 in. – 18 NPT-f direct	(Notes 3, 17, 30)		NACE						M			
	Hastelloy® C-276 (Vertical connection)	1/2 in. – 14 NPT-f through adapter	(Notes 3, 17, 30)		NACE						S			
	Monel 400® (Vertical connection)	1/4 in. – 18 NPT-f direct	(Notes 3, 4, 17, 30)		NACE						U			
	Monel 400® (Vertical connection)	1/2 in. – 14 NPT-f through adapter	(Notes 3, 4, 17, 30)		NACE						V			
	PVDF Kynar® insert on AISI 316 ss flange side	1/4 in. – 18 NPT-f direct	(Notes 5, 6, 17, 30)								P			
	PVDF Kynar® insert on AISI 316 ss flange side	1/2 in. – 14 NPT-f direct	(Notes 5, 6, 17, 30)								Z			
	Flange mounted version (REFER TO "F26" ACCESSORY CODE FOR QUOTE)		(Notes 2, 6, 17, 30)								R			
Bolts/Gasket (wetted parts) - 11th character														
	For standard static, high static and gauge versions	AISI 316 ss	Viton®	(Notes 4, 7, 27, 30)	NACE (non exposed)						1			
		→ AISI 316 ss	PTFE	(Notes 1, 4, 7, 27)	NACE (non exposed)						2			
	For standard static, gauge and flange mounted versions	AISI 316 ss – MWP = 16 MPa	Viton®	(Notes 7, 30)	NACE						3			
		AISI 316 ss – MWP = 16 MPa	PTFE	(Notes 1, 7)	NACE						4			
	For high static version	Stainless steel – MWP = 42 MPa	Viton®	(Notes 7, 27, 30)	NACE						3			
		Stainless steel – MWP = 42 MPa	PTFE	(Notes 1, 7, 27)	NACE						4			
	For standard static, high static and gauge versions	Alloy steel	Viton®	(Notes 4, 7, 27, 30)	NACE						8			
		Alloy steel	PTFE	(Notes 1, 4, 7, 27, 30)	NACE						9			
	For PVDF Kynar process connection	AISI 316 ss spring loaded – MWP = 1 MPa		(Notes 8, 27, 30)	NACE						N			
Housing material and electrical connection - 12th character														
→	Aluminium alloy (barrel version)	1/2 in. – 14 NPT							(Note 21)		A			
	Aluminium alloy (barrel version)	M20 x 1.5 (CM 20)		(TO BE USED for WirelessHART)					(Note 30)		B			
	AISI 316 L ss (barrel version) (I2 or I3 required)	1/2 in. – 14 NPT							(Note 21)		S			
	AISI 316 L ss (barrel version) (I2 or I3 required)	M20 x 1.5 (CM20)		(TO BE USED for WirelessHART)					(Note 30)		T			
	Aluminium alloy (DIN version)	M20 x 1.5 (CM20)		(not Ex d or XP)					(Notes 21, 30)		J			
Output/Additional options - 13th character														
	HART and 4 to 20 mA - Standard functionality													7
→	HART and 4 to 20 mA - Advanced functionality (includes option R1)													1
	PROFIBUS PA (includes option R1)													2
	FOUNDATION Fieldbus (includes option R1)													3
	HART and 4 to 20 mA Safety, certified to IEC 61508 (includes option R1)								(Note 30)					8
	WirelessHART (includes option R1)								(Notes 20, 30)					9

NOTE - Option R1 represents the external pushbuttons

Additional ordering information for model 266DSH Differential Pressure Transmitter

Add one or more 2–digit code(s) after the basic ordering information to select all required options.

				XX	XX	XX	XX
Accuracy							
0.04 % accuracy for applicable ranges				(Notes 7, 17, 18, 21, 27)	D2		
Drain/vent valve (material and position) (wetted parts)							
AISI 316 L ss	on process axis	(Notes 7, 9)	NACE			V1	
→ AISI 316 L ss	on flange side top	(Notes 7, 10, 17)	NACE			V2	
AISI 316 L ss	on flange side bottom	(Notes 7, 10, 17)	NACE			V3	
Hastelloy® C-276	on process axis	(Notes 7, 11)	NACE			V4	
Hastelloy® C-276	on flange side top	(Notes 7, 12, 17)	NACE			V5	
Hastelloy® C-276	on flange side bottom	(Notes 7, 12, 17)	NACE			V6	
Monel 400®	on process axis	(Notes 7, 13, 17)	NACE			V7	
Monel 400®	on flange side top	(Notes 7, 14, 17)	NACE			V8	
Monel 400®	on flange side bottom	(Notes 7, 14, 17)	NACE			V9	
Hazardous area certifications (see relevant paragraph for complete detailed markings)							
ATEX Intrinsic Safety Ex ia				(Note 30)			E1
ATEX Explosion Proof Ex db				(Notes 15, 21, 30)			E2
ATEX Intrinsic Safety Ex ic				(Notes 21, 30)			E3
Combined ATEX, IECEx, FM Approvals (USA) and FM Approvals (Canada)				(Notes 15, 21, 30)			EN
FM Approvals (Canada) approval (XP, DIP, IS, NI, Type N)				(Notes 15, 21)			E4
→	FM Approvals (USA) approval (XP, DIP, IS, NI, Type N)			(Notes 15, 21)			E6
FM Approvals (USA and Canada) Intrinsically Safe							EA
IECEx Intrinsic Safety Ex ia				(Note 30)			E8
IECEx Explosion Proof Ex db				(Notes 15, 21, 30)			E9
IECEx Intrinsic Safety Ex ic				(Notes 21, 30)			ER
NEPSI Intrinsic Safety Ex ia				(Notes 21, 30)			EY
NEPSI Explosion Proof Ex d				(Notes 15, 21, 30)			EZ
NEPSI Intrinsic Safety Ex ic				(Notes 21, 30)			ES
Other hazardous area certifications (ONLY AS ALTERNATIVE TO BASIC CERTIFICATION CODE Ex)							
Technical Regulations Customs Union (EAC) Intrinsic Safety Ex ia for Russia				(Notes 21, 30)			W1
Technical Regulations Customs Union (EAC) Explosion Proof Ex d for Russia				(Notes 15, 21, 30)			W2
Technical Regulations Customs Union (EAC) combined Ex ia and Ex d for Russia				(Notes 15, 21, 30)			WC
Technical Regulations Customs Union (EAC) Intrinsic Safety Ex ia for Kazakhstan				(Notes 21, 30)			W3
Technical Regulations Customs Union (EAC) Explosion Proof Ex d for Kazakhstan				(Notes 15, 21, 30)			W4
Technical Regulations Customs Union (EAC) combined Ex ia and Ex d for Kazakhstan				(Notes 15, 21, 30)			WD
Inmetro (Brazil) Intrinsic Safety Ex ia				(Notes 21, 30)			W5
Inmetro (Brazil) Explosion Proof Ex d				(Notes 15, 21, 30)			W6
Inmetro (Brazil) Intrinsic Safety Ex ic				(Notes 21, 30)			W7
Combined Inmetro (Brazil) - Intrinsic Safety Ex ia, Explosion Proof and Intrinsic Safety Ex ic				(Notes 15, 21, 30)			W8
Technical Regulations Customs Union (EAC) Intrinsic Safety Ex ia for Belarus				(Notes 21, 30)			WF
Technical Regulations Customs Union (EAC) Explosion Proof Ex d for Belarus				(Notes 15, 21, 30)			WG
Technical Regulations Customs Union (EAC) combined Ex ia and Ex d for Belarus				(Notes 15, 21, 30)			WH
Kosha (Korea) Intrinsic Safety Ex ia IIC T6, IP67				(Notes 19, 21, 30)			WM
Kosha (Korea) Explosion Proof Ex d IIC T6, IP67				(Notes 15, 19, 21, 30)			WN
Combined Kosha (Korea) - Intrinsic Safety and Explosion Proof				(Notes 15, 19, 21, 30)			WP

... Additional ordering information for model 266DSH Differential Pressure Transmitter

	XX	XX	XX	XX	XX	XX
Approvals						
Metrologic Pattern for Russia (NOT APPLICABLE WITH ANY HAZARDOUS AREA CERTIFICATION) (Note 30)	Y1					
Metrologic Pattern for Kazakhstan (NOT APPLICABLE WITH ANY HAZARDOUS AREA CERTIFICATION) (Note 30)	Y2					
Metrologic Pattern for Belarus (NOT APPLICABLE WITH ANY HAZARDOUS AREA CERTIFICATION) (Note 30)	Y4					
Chinese pattern (NOT APPLICABLE WITH ANY HAZARDOUS AREA CERTIFICATION) (Note 30)	Y5					
DNV GL approval (Notes 19, 21)	YA					
Approval for Custody transfer (PENDING)	YC					
Conformity to NAMUR NE 021 (2004) (NOT APPLICABLE WITH SURGE PROTECTOR CODE "S2") (Notes 19, 21, 24, 26)	YE					
NSF/ANSI 61 Drinking Water Certified	YN					
CRN (Canadian Registration Number OF14838.5C)	YR					
Material traceability						
Inspection certificate EN 10204–3.1 of process wetted parts (not for gaskets)					H3	
Test report EN 10204–2.2 of pressure bearing and process wetted parts (not for gaskets)					H4	
National radio frequency licence						
Basic countries (Europe, USA, Canada)						FB
Argentina						FA
United Arab Emirates						FG
India						FI
Mexico						FM
Electrical connection plug						
One certified stainless steel plug (supplied loose with thread according to housing entries)						Z1
Accessory						
Manifold mounting and pressure test (NOT AVAILABLE WITH OXYGEN SERVICE CLEANING - PREPARATION PROCEDURE CODE P1 or WITH VERTICAL FLANGES WHEN SELECTED WITH BRACKET CODE Bx) (Notes 7, 23, 27, 30)						A1

...Ordering information

Accessory ordering information model 266DSH flanged mounted version

Select one character or set of characters from each category and specify complete additional catalog number.

BASE MODEL - 1st to 3rd characters			F 2 6	X	X	X	X
Process connections of flange mounted version							
Construction - 4th character							
Differential				F			
HIGH PRESSURE SIDE - Process mounting flange rating / Size - 5th characters							
ASME Class 150		2 in.				A	
ASME Class 150		3 in.				B	
ASME Class 300		2 in.				D	
ASME Class 300		3 in.				E	
EN PN 16 / 40		DN 50				M	
EN PN 16		DN 80				N	
EN PN 40		DN 80				L	
HIGH PRESSURE SIDE - Mounting flange material/seat form - 6th characters							
AISI 316 L ss	Form RF (raised face) - serrated finish		(Note 28)	NACE			D
AISI 316 L ss	EN 1092-1 Type B1 - serrated finish		(Note 29)	NACE			L
LOW PRESSURE SIDE - Process flanges/adapters material and connection (wetted parts) - 7th character							
AISI 316 L ss (Horizontal connection)		1/4 in. – 18 NPT-f direct		NACE			A
AISI 316 L ss (Horizontal connection)		1/2 in. – 14 NPT-f through adapter		NACE			B

- Note 1: Suitable for oxygen service
- Note 2: Not available with sensor code A and B
- Note 3: Not available with AISI 316L ss or Hastelloy C-276 (on AISI seat) diaphragms code S, H, A, L
- Note 4: Not available with sensor code A
- Note 5: Not available with Diaphragm material/Fill fluid code S, H, K, M, A, F, C, L, P, 4
- Note 6: Not available with sensor code A, Q, S
- Note 7: Not available with Process Flanges/Adapters material/connection code P, Z
- Note 8: Not available with Process Flanges/Adapters material/connection code A, B, D, E, G, H, Q, T, M, S, U, V, Y, W
- Note 9: Not available with Process flanges/adapters material/connection code D, E, G, H, Q, T, M, S, U, V, Y, W
- Note 10: Not available with Process flanges/adapters material/connection code D, E, G, H, M, S, U, V
- Note 11: Not available with Process flanges/adapters material/connection code A, B, G, H, Q, T, M, S, U, V, Y, W, R
- Note 12: Not available with Process flanges/adapters material/connection code A, B, G, H, Q, T, U, V, Y, W, R
- Note 13: Not available with Process flanges/adapters material/connection code A, B, D, E, Q, T, M, S, U, V, Y, W, R
- Note 14: Not available with Process flanges/adapters material/connection code A, B, D, E, Q, T, M, S, Y, W, R
- Note 15: Not available with Housing code J
- Note 16: Not available with sensor code E, F, G, H, M, P, Q, and S
- Note 17: Not available with high static pressure code H
- Note 18: Not available with sensor code A, B, E, S
- Note 19: Not available with Output code 7
- Note 20: Not available with Housing code A, S, J
- Note 21: Not available with Output code 9
- Note 22: Not available with Output code 1, 2, 3, 7, 8
- Note 23: Not available with Process Flanges/Adapters material/connection code B, E, W, H, T, S, V
- Note 24: Not available with Output code 2, 3
- Note 25: Not available with Hazardous area certification code WM, WN, WP
- Note 26: Not available with Hazardous area certification code EN, E4, E6, EA, EY, EZ, ES, W1, W2, WC, W3, W4, WD, W5, W6, W7, W8, WF, WG, WH, WM, WN, WP
- Note 27: Not available with flange mounted version - Process flanges/adapters material/connection code R
- Note 28: Not available with EN mounting flange code M, N, L
- Note 29: Not available with ASME mounting flange code A, B, D, E
- Note 30: Not available NSF/ANSI 61 approval code YN
- Note 31: Not available with Output code 2, 3, 9

Standard delivery items (can be differently specified by additional ordering code)

- Adapters supplied loose
- Plug on axis of horizontal connection flange or on side bottom for horizontal connection flange with MWP= 16 MPa; nothing for PVDF Kynar insert or for vertical connection flange (no drain/vent valves)
- General purpose (no electrical certification)
- No display, no mounting bracket, no surge protection
- Short-form operating instruction manual and labels in english (metal nameplate; self-adhesive certification and tag)
- Configuration with kPa and deg. C units
- No test, inspection or material traceability certificates

IMPORTANT REMARK FOR ALL MODELS

THE SELECTION OF SUITABLE WETTED PARTS AND FILLING FLUID FOR COMPATIBILITY WITH THE PROCESS MEDIA IS A CUSTOMER'S RESPONSIBILITY, IF NOT OTHERWISE NOTIFIED BEFORE MANUFACTURING.

NACE COMPLIANCE INFORMATION

- 1 The materials of constructions comply with metallurgical recommendations of NACE MR0175/ISO 15156 for sour oil field production environments. As specific environmental limits may apply to certain materials, please consult latest standard for further details. AISI 316/316 L, Hastelloy C-276, Monel 400 also conform to NACE MR0103 for sour refining environments.
- 2 NACE MR-01-75 addresses bolting requirements in two classes:
 - Exposed bolts: bolts directly exposed to the sour environment or buried, encapsulated or anyway not exposed to atmosphere
 - Non exposed bolts: the bolting must not be directly exposed to sour environments and must be directly exposed to the atmosphere at all times.

266DSH bolting identified by "NACE (non exposed)" are in compliance with requirements of NACE MR0103 when considered "non exposed bolting".

266DSH bolting identified by "NACE" are in compliance with requirements of NACE MR0175 when considered "exposed bolting".

® Hastelloy is a registered trademark of Haynes International

® Monel and Inconel are registered trademarks of Special Metals Corporation

® Galden is a registered trademark of Solvay Group

® Halocarbon is a registered trademark of Halocarbon Products Co.

® HART and WirelessHART are registered trademarks of HART Communication Foundation

® PROFIBUS is a registered trademark of Profibus International

™ FOUNDATION Fieldbus is a trademark of Fieldbus Foundation

ABB Ltd.**Measurement & Analytics**

Howard Road St. Neots
Cambridgeshire PE19 8EU
UK

Tel: +44 (0)1480 475321

Fax: +44 (0)1480 217948

ABB S.p.A.**Measurement & Analytics**

Via Luigi Vaccani 4
22016 Tremezzina (CO)
Italy

Tel: +39 0344 58111

ABB Inc.**Measurement & Analytics**

125 E. County Line Road
Warminster PA 18974
USA

Tel: +1 215 674 6000

Fax: +1 215 674 7183

abb.com/measurement

We reserve the right to make technical changes or modify the contents of this document without prior notice. With regard to purchase orders, the agreed particulars shall prevail. ABB does not accept any responsibility whatsoever for potential errors or possible lack of information in this document.

We reserve all rights in this document and in the subject matter and illustrations contained therein. Any reproduction, disclosure to third parties or utilization of its contents – in whole or in parts – is forbidden without prior written consent of ABB.

Three-Valve Manifolds

.187" ORIFICE

Description

1/2" FNPT x 1/2" FNPT

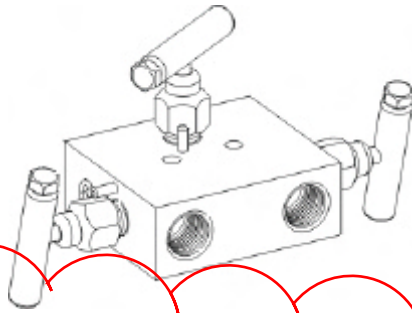

Body Style

M-500 Hard Seat

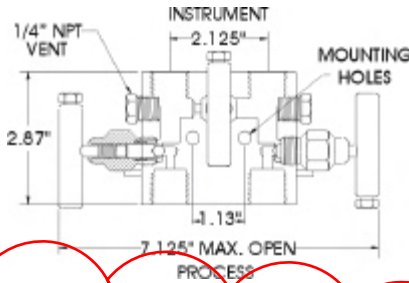

M-501 Soft Seat

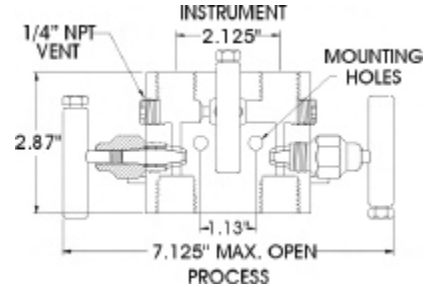

1/2" FNPT x Flange

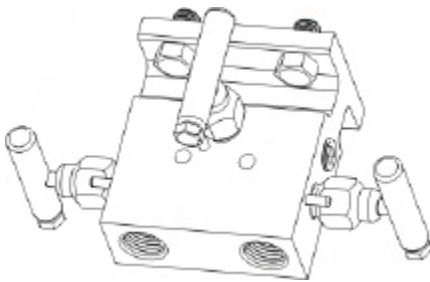

M-650 Hard Seat

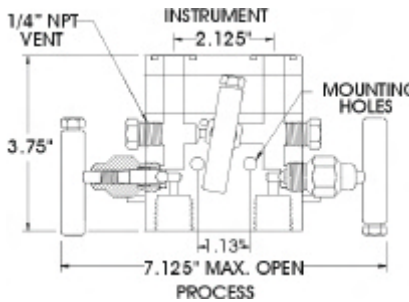

M-651 Soft Seat

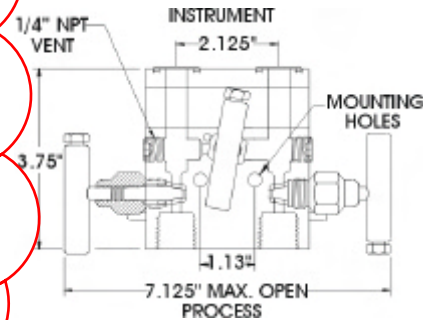

Flange x Flange

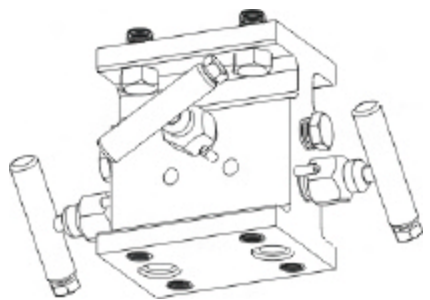

M-750 Hard Seat

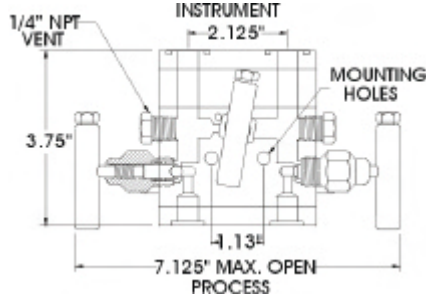

M-751 Soft Seat

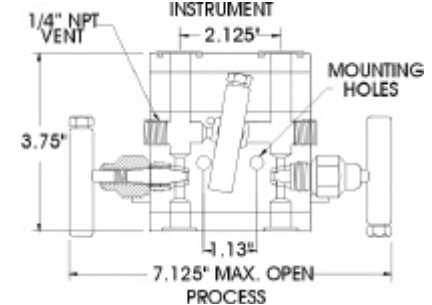

MATERIALS OF CONSTRUCTION

SEAT	MAX Cv RATINGS
Hard Ball	.53
Soft Cone	.83
Approx. Manifold Weight:	4.2 lbs each [M-500 / 501]
	5.2 lbs each [M-650 / 651]
	5.7 lbs each [M-750 / 751]

PART DESCRIPTION	CARBON STEEL	A105 CARBON STEEL	316 SS	MONEL®	HASTELLOY-C®
Body	ASTM A108-1215	ASTM A105 CF	ASTM A479-316	ASTM B164-N04405 or ASTM B164-N04400	ASTM B575-N10276 or ASTM A494 CW-12MW
Bonnet	ASTM A108-1215	ASTM A479-316	ASTM A479-316	ASTM B165-N04405	ASTM B574-N10276
Stem	ASTM A582-303	ASTM A479-316	ASTM A479-316	ASTM B164-N04405	ASTM B574-N10276
Seal Retainer	ASTM A479-316	ASTM A479-316	ASTM A479-316	ASTM B164-N04405	ASTM B574-N10276
Handle Assembly	ASTM A108	ASTM A108	ASTM A582 (18-8)	ASTM A582 (18-8)	ASTM A582 (18-8)
Plug(s)	ASTM A108	ASTM F593 (18-8)	ASTM A182-F (18-8)	ASTM B164-N04405	ASTM B574-N10276
Mounting Bolts	ASTM A449-TYPE 1	ASTM A449-TYPE 1	ASTM A449-TYPE 1	ASTM F593 (18-8)	ASTM F593 (18-8)

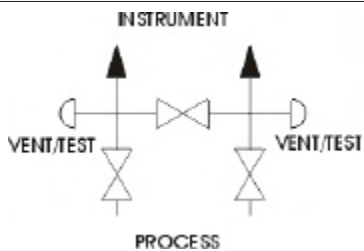

- Carbon Steel Manifolds are Zinc Cobalt Plated with Dichromate Dip
- 316 SS Manifolds Meet NACE MR0175 Requirements (Latest Revision)
- 100% Pressure Tested
- Carbon Steel Weld End Connection Bodies are AISI 1018

Three-Valve Manifolds

.187" ORIFICE

THREE-VALVE MANIFOLDS

ORDERING INFORMATION

BODY STYLE	BODY CODE	SEAT CODE	STEM SEAL CODE	OPTION CODES
Hard Seat				
M - 500				
M - 650	S	C	T	W9
M - 750				
Soft Seat				
M - 501				
M - 651				
M - 751				

BODY CODE	
[Std.] Carbon Steel	C
A105 Carbon Steel	P
[Std.] 316 SS	S
Monel®	M
Hastelloy-C®	H

HARD SEAT CODE		SOFT SEAT CODE	
[Std.] Carbide Ball	C	Delrin® Cone [Std.]	D
Ceramic Ball	R	Kel-F® Cone	K
316 SS Ball	6	PEEK® Cone	P
K-Monel® Ball	N	Teflon® Cone	T
Hastelloy-C® Ball	H	Tefzel Cone	Z

STEM SEAL CODE	
[Std.] Teflon® Pressure-Core™	T
Teflon® Pressure-Core™ Back-up	K
Grafoil® Packed	G
Viton® O-Ring	V
Low-Temp Pressure-Core™	J
Teflon® Packed [Hard Seat Only]	P

OPTIONS

- Versa-Mount Brackets
- Bonnet Handle Lock-Out
- Bonnet Lock Plates
- Steam Trace Block
- Integral Tube Fitting Connections

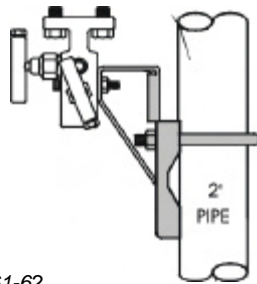

See Options/Accessories Pages 61-62.

PRESSURE & TEMPERATURE

BODY MATERIAL	HARD SEAT Teflon Pressure-Core CODE T	HARD SEAT Teflon Pressure-Core CODE K	HARD SEAT Grafoil
	Carbon Steel Code C	10,000 PSI @ 200° F 8,000 PSI @ 450° F	6,000 PSI @ 400° F
A105 Carbon Steel Code P	10,000 PSI @ 200° F 8,000 PSI @ 450° F	Not Available	6,000 PSI @ 200° F 1,500 PSI @ 800° F
316 SS Code S	10,000 PSI @ 200° F 8,000 PSI @ 450° F	6,000 PSI @ 400° F	6,000 PSI @ 200° F 1,500 PSI @ 1,000° F
See Page 5: Chart D			
BODY MATERIAL	SOFT SEAT (Delrin) Teflon Pressure-Core CODE T	SOFT SEAT (Peek) Teflon Pressure-Core CODE T	
	Carbon Steel Code C	6,000 PSI @ 200° F	10,000 PSI @ 200° F 3,000 PSI @ 400° F
316 SS Code S	6,000 PSI @ 200° F	10,000 PSI @ 200° F 3,000 PSI @ 400° F	
See Page 5: Chart A			

OPTION CODE	OPTION DESCRIPTION
AU7	½" Integral Tube Fitting - Parker® A-LOK Dual Ferrules (Process Ports)
AV7	½" Integral Tube Fitting - Swagelok® Dual Ferrules (Process Ports)
GA	Anti-Tamper Bonnet (All Positions)
GC	Anti-Tamper Bonnet (Isolate Valve(s) Only)
GD	Anti-Tamper Bonnet (Equalizer Valve(s) Only)
GJ	Bonnet Lock-Out (All Positions - Lock Not Provided)
GK	Bonnet Lock-Out (Isolate Valve(s) Only - Lock Not Provided)
GL	Bonnet Lock-Out (Equalizer Valve(s) Only - Lock Not Provided)
ME	Slotted Instrument Flange Using Bolts over 3"
MH	Viton® O-Ring Flange Seals
MU	Dielectric Isolation (Flange Manifolds Only)
M7	Required Slotting for Rosemount® 1151 Transmitters Series 6 & Above (Flange Manifolds Only)
PB	(2) ¼" Constant Purge Ports (Bottom) See pg. 61 for port locations.
PT	(2) ¼" Constant Purge Ports (Top) See pg. 61 for port locations.
P1	Purge or Test Connections
TC	Steam Trace Block - Carbon Steel
TH	Hydrostatic Testing
TS	Steam Trace Block - 316 SS
VA	Bracket Spacer for Flange to Flange Manifolds
VC	CS Versa-Mount Bracket
VS	316 SS Versa-Mount Bracket
VCH	CS Heavy-Duty Versa-Mount Bracket
VSH	316 SS Heavy-Duty Versa-Mount Bracket
W	Safety Bonnet Lock Plate
WA	CS
WAW3	300 SS 2-¼" Bolts for Rosemount® 3051C, 3095, or 2024 with Coplanar™ (Flange Manifolds Only)
WAW9	316 SS
WK	Paper Tag
W1	316 SS Tag (20 Characters - See page 61)
W3	300 SS Standard Length Flange Bolts (CS Standard)
W9	316 SS Standard Length Flange Bolts (CS Standard)
XL	Clean for Critical Service (Oxygen or Chlorine)
X3	(2) ¼" Test Ports on Instrument Flange (Flange Manifolds Only) See pg. 61 for port locations.

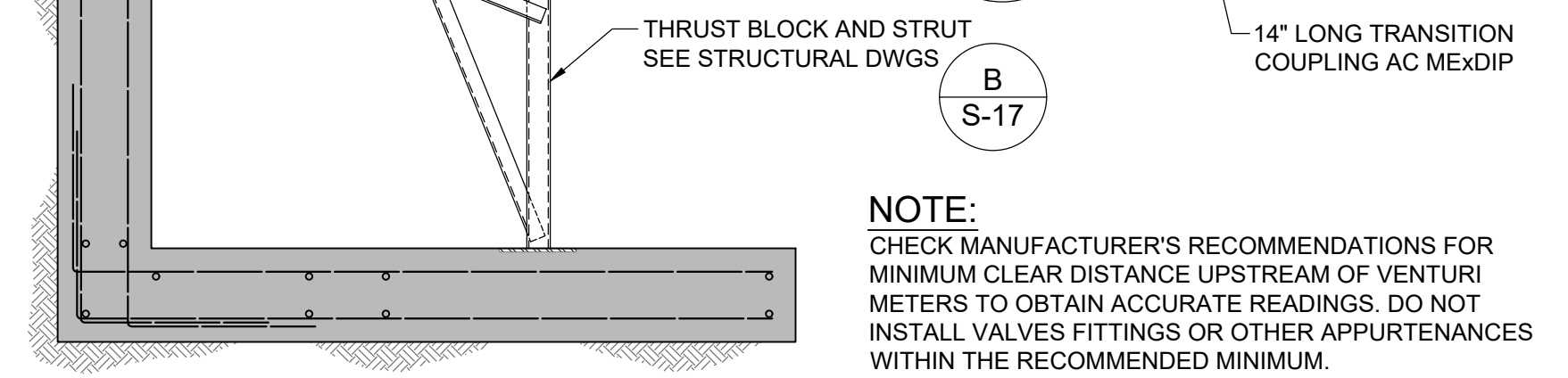
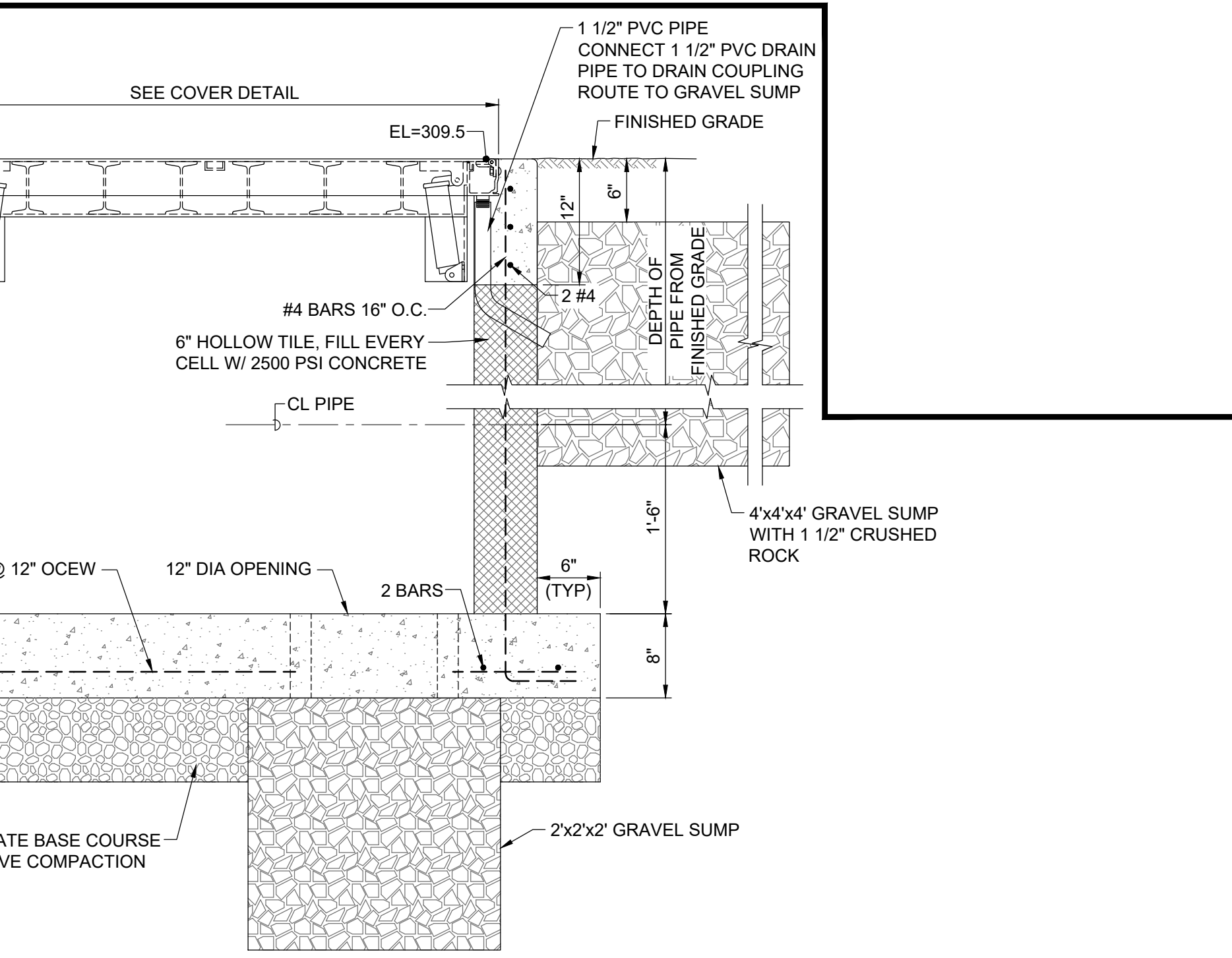
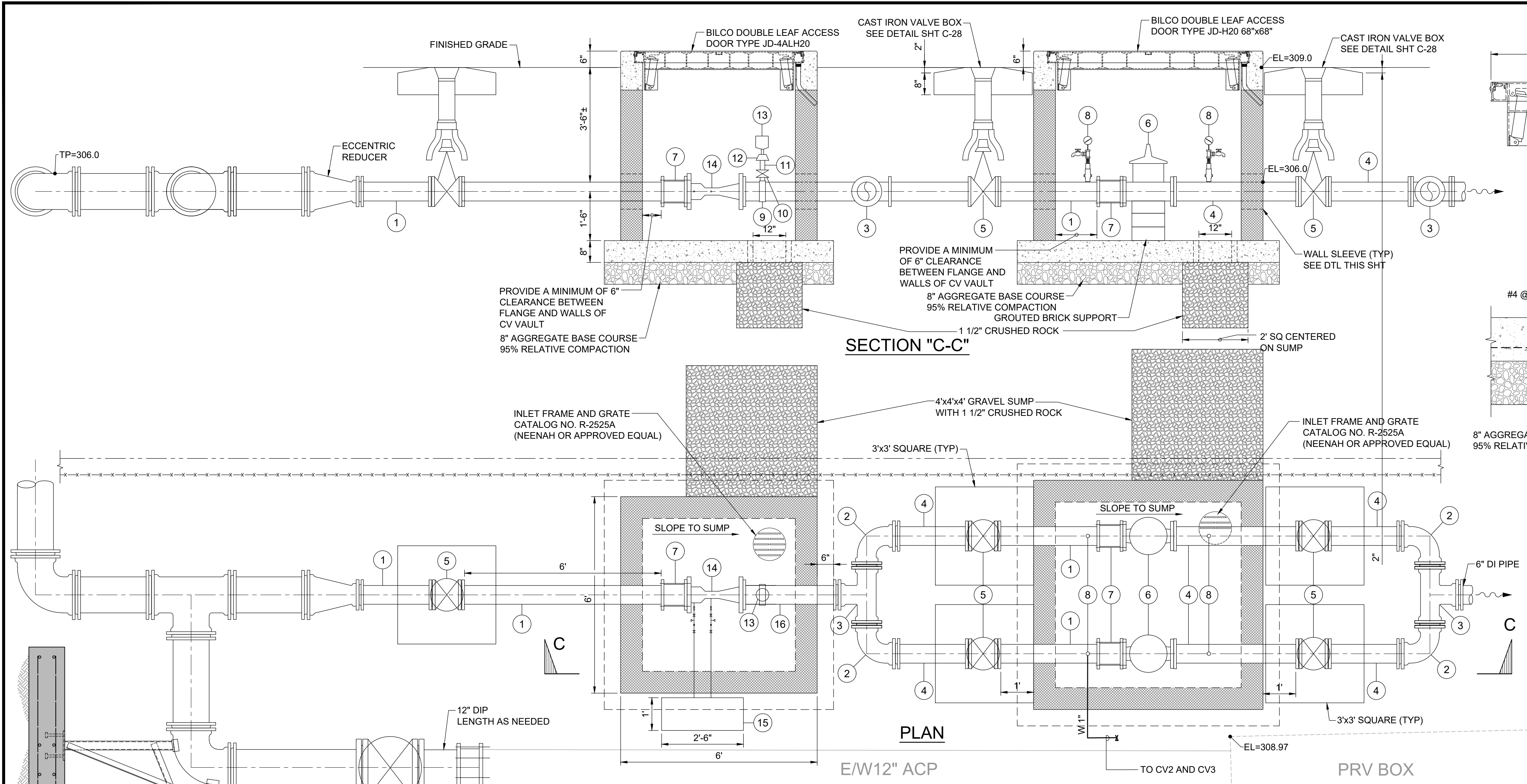

ITEM NO.	DESCRIPTION
1	6" NIPPLE, 24" MIN, PE&PE
2	6" 1/4 BEND, W/CONC BLOCK, FE
3	6" TEE, W/CONC BLOCK, FE
4	6" PIPE, LENGTH TO FIT, FE&PE
5	6" GATE VALVE WITH HAND WHEEL, MJ W/MEGALUG RETAINER GLANDS
6	*6" CLA-VAL COMBINATION BACK PRESSURE AND SOLENOID SHUTOFF VALVE, MODEL 6" 658-01 WITH 4-20 MA POSITION TRANSMITTER. SET BACK PRESSURE TO 55 PSI
7	6" FLANGED COUPLING ADAPTER WITH SS RODS
8	MARSH STANDARD PRESSURE GAUGE, TYPE 1, 0-125 PSI OR EQUAL AND 3/4" HOSE BIBB W/O CHECK (WITH INSECT SCREEN)
9	6" SS DOUBLE STRAP SERVICE SADDLE - STAINLESS STEEL
10	1" CORP STOP, BALL TYPE, THREADED 1"MIPTx1"FIPT
11	1" NIPPLE, BRASS
12	1"x1/2" REDUCER, BRASS
13	*ROSEMOUNT PRESSURE TRANSMITTER, 1/2 MIPT, 4-20mA MODEL NUMBER 3051TG2A2A21 JB4Q4-T1
14	*6" BIF UNIVERSAL VENTURI TUBE, MODEL 6B 20181 OR 6" PFS HALMI VENTURI METER, MODEL HVT-FV, BOTH WITH STAINLESS STEEL TYPE 316, FE
15	DIFFERENTIAL PRESSURE TRANSMITTER (SEE DETAIL THIS SHEET) 2 LEGGED PIPE STAND ABB 266DSH TRANSMITTER W/ 3-VALVE MANIFOLD
16	6" SPOOL, LENGTH TO FIT, FE

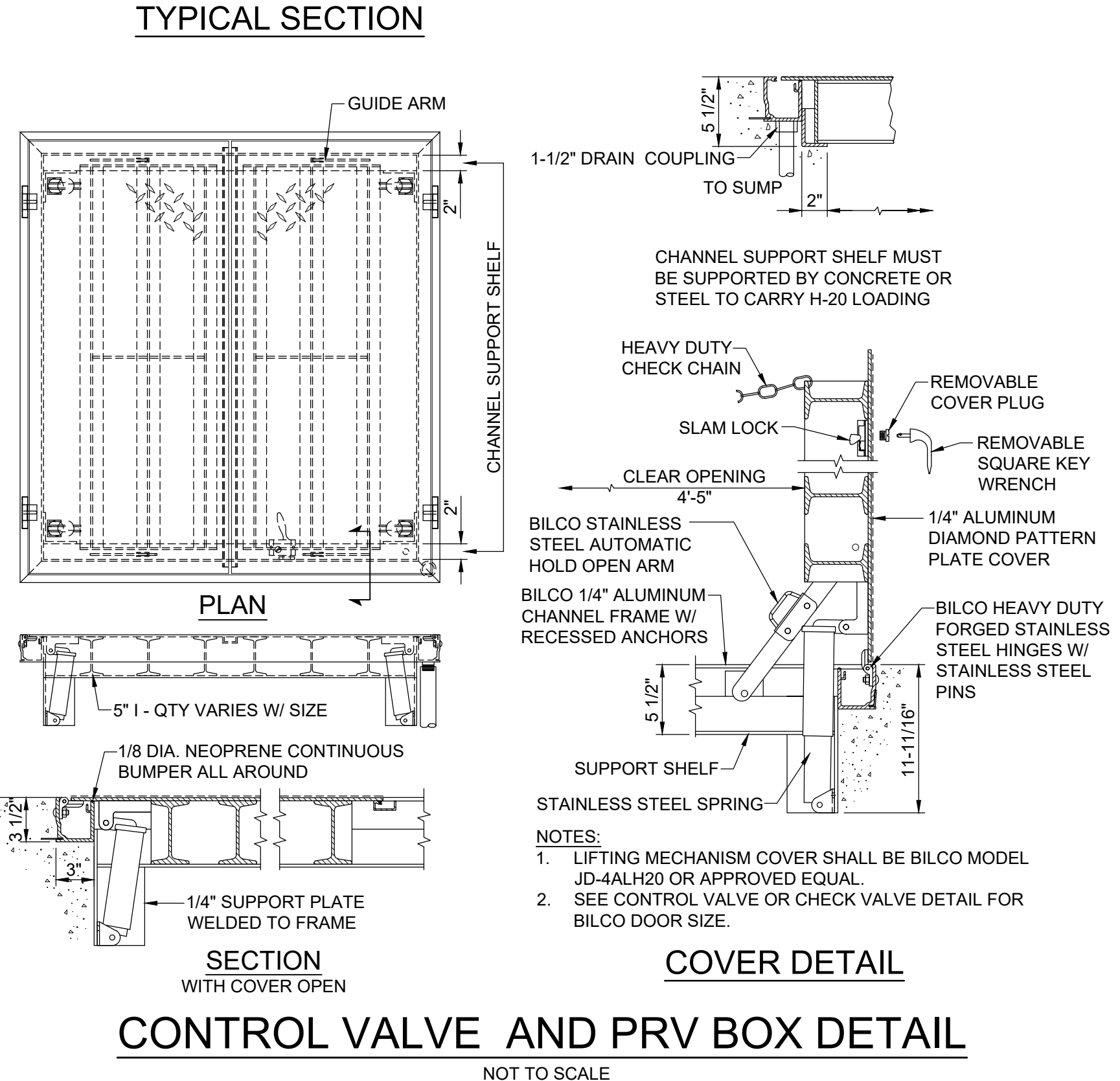
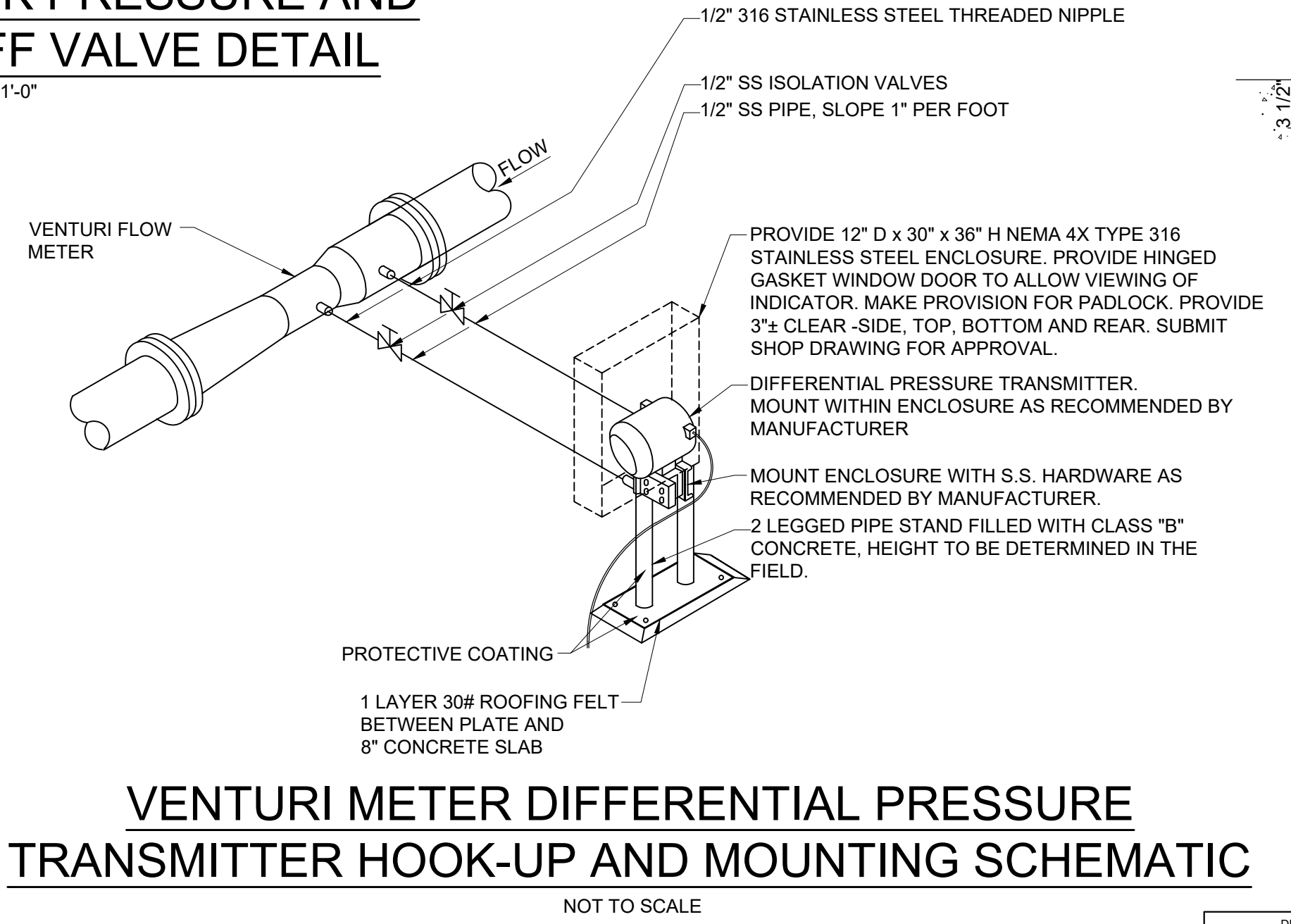
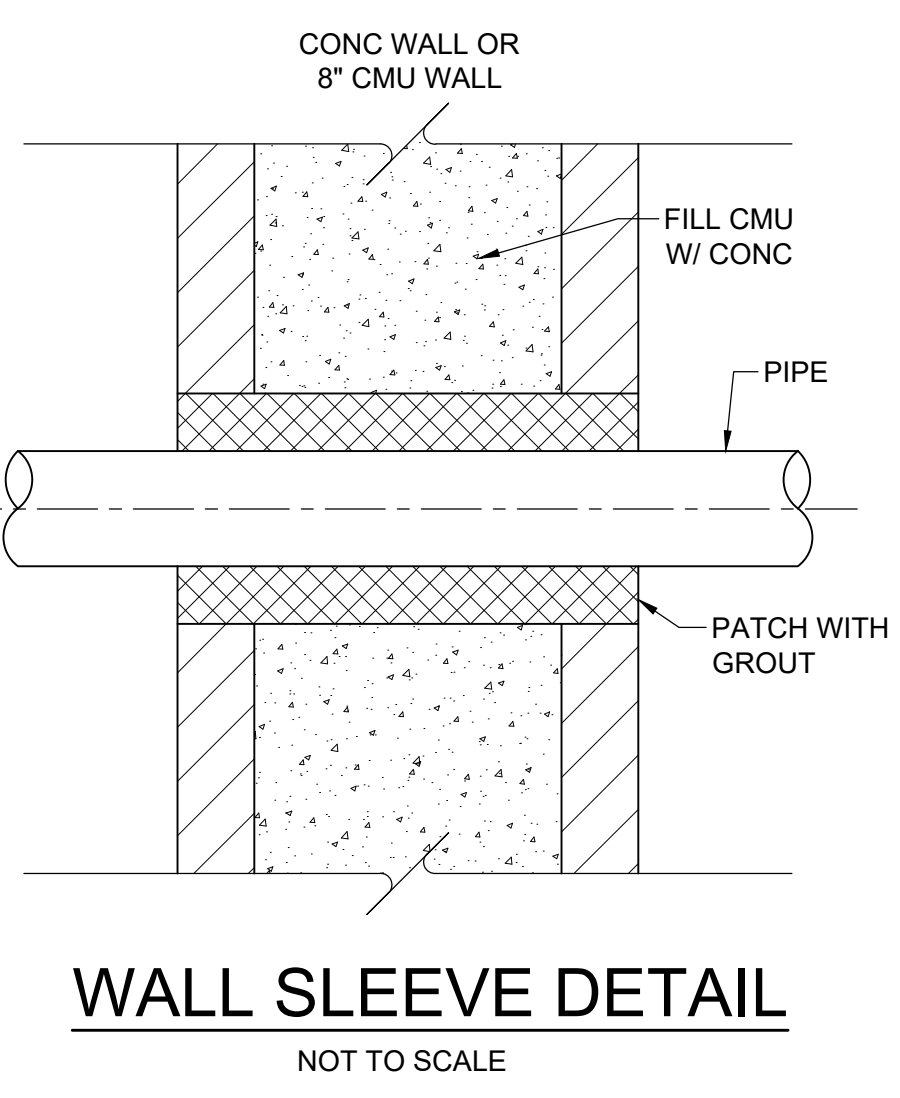

CONTROL VALVE AND PRV BOX DETAIL

REVISION	DATE	DESCRIPTION	APPROVED

TMK: 4 - 6 - 011:003



APPROVED: *Cary K. Kondo*
 COUNTY ENGINEER, DEPARTMENT OF PUBLIC WORKS
 COUNTY OF KAUAI (FOR WORK WITH COUNTY RW)

BELT COLLINS HAWAII LLC
 2153 North King Street, Suite 200
 Honolulu, Hawaii 96819
 JOB NO. 02-14, WK-08
KAPA'A HOMESTEADS 325' TANKS
 TWO 0.5 MG TANKS
 PACKAGE B - TANKS PACKAGE
 WAILUA-KAPA'A WATER SYSTEM
 KAPA'A, KAUAI, HAWAII
PIPING DETAILS-1

APPROVED: *Jason Kagimoto*
 COUNTY ENGINEER, DEPARTMENT OF WATER
 COUNTY OF KAUAI

DRAWING NO.
C-16

1/27/2023 3:44:49 PM T:\KAPAA_HOMESTEADS_TANK\2024\740100_WAIPAAI_TANK\CAD_SHEETS\CONSTRUCTION\PLAN-C\16_PIPING_DETAILS-1.DWG
 HALF SIZE TRIMLINE FOR 11" X 17"

IFB Job No. 02-14, WK-08
Material Substitution Request No. 3
(DENIED-6 pages)



ARCHITECTURAL SPECIALTIES * 2538 Alaula Way, Honolulu, HI 96822

March 7, 2023

Procurement Officer
Jason Kagimoto
Engineering Division
Department of Water, County of Kaua'i
4398 Pua Loke St. Suite 1600
Lihue, HI 96766

SUBJECT: SUBSTITUTION REQUEST
PROJECT TITLE: WK-08, KAPA'A HOMESTEADS 325' TANKS,
TWO 0.5 MG TANKS, PACKAGE B – TANKS PACKAGE
KAPA'A, KAUA'I, HAWAII

In accordance with the GENERAL PROVISIONS for construction, enclosed are sets of technical brochures and statement of variances for your review and approval for the item(s) shown below:

SECTION/ ITEM	SPECIFIED BRAND(S)	SUBSTITUTE OR ALTERNATE BRAND	VARIANT FEATURES
SP-6/ Aluminum Horizontal Access Doors	Bilco	Babcock-Davis	None

I certify that the substitution request of the above item(s) has no other variant features.

A handwritten signature in cursive script that reads "Kimo Ryan".

Kimo Ryan
President

Tel: (808) 773-7478 * e-mail: DivisionXOffice@divxhi.com

SECTION SP-6 – ALUMINUM HORIZONTAL ACCESS DOORS

6.01 GENERAL: Work includes furnishing and installing factory-fabricated vault access doors.

6.02 REFERENCES:

The publications listed below form a part of this specification to the extent referenced. The publications are referred to in the text by the basic designation only. Where a referenced document contains references to other standards, those documents are included as references under this section as if referenced directly. In case of conflict between the requirements of this specification and those of the listed documents, the requirements of this specification shall prevail.

Unless otherwise specified, references to documents shall mean the documents in effect at the time of Advertisement for Invitation for Bids (IFB). If referenced documents have been discontinued by the issuing organization, references to those documents shall mean the replacement documents issued or otherwise identified by that organization or, if there are no replacement documents, the last version of the document before it was discontinued. Where document dates are given in the following listing, references to those documents shall mean the specific document version associated with that date, regardless of whether the document has been superseded by a version with a later date, discontinued, or replaced.

1. ASTM A 36-93a: Standard Specification for Structural Steel.

6.03 SUBMITTALS: The Contractor shall submit manufacturer's product data for all materials in this specification. Shop drawings must show profiles, accessories, location and dimensions. Manufacturer to provide samples upon request; sized to represent material adequately. Vault access door manufacturer shall provide Manufacturer's Warranty.

6.04 PRODUCT HANDLING: All materials shall be delivered in manufacturer's original packaging. Materials must be stored in a dry, protected, well-vented area. The Contractor shall thoroughly inspect product upon receipt and report damaged material immediately to the delivery carrier and note such damage on the carrier's freight bill of lading.

6.05 JOB CONDITIONS: The Contractor shall verify that other trades with related work are complete before installing vault access door(s). Mounting surfaces shall be straight and secure; substrates shall be of proper width. Refer to construction documents, shop drawings, and manufacturer's installation instructions. Contractor shall observe all appropriate OSHA safety guidelines for this work.

6.06 WARRANTY / GUARANTEE: Manufacturer's standard warranty: Materials shall be free of defects in material and workmanship for a period of twenty-five (25) years from the date of purchase. Should a part fail to function in normal use within this period, manufacturer shall furnish a new part at no charge. Electric motors, special finishes, and other special equipment shall be warranted separately by the manufacturers of those products.

6.07 MANUFACTURER: Aluminum horizontal access doors shall be as manufactured by The Bilco Company or approved equal.

6.08 ACCESS DOOR:

- A. The Contractor shall furnish and install where indicated on the plans, vault access doors. Type, size, and hinge side shall be as indicated on the plans.
- B. Performance characteristics:
 - (1) Covers: Shall be reinforced to support AASHTO H-20 wheel load with a maximum deflection of 1/150th of the span. Manufacturer to provide structural calculations stamped by a registered professional engineer licensed in the State of Hawai'i.
 - (2) Operation of the covers shall be smooth and easy with controlled operation throughout the entire arc of opening and closing.
 - (3) Operation of the covers shall not be affected by temperature.
 - (4) Entire door, including all hardware components, shall be highly corrosion resistant.
- C. Covers: Shall be ¼" (6.3 mm) aluminum diamond pattern.
- D. Frame: Channel frame shall be ¼" (6.3 mm) extruded aluminum with bend down anchor tabs around the perimeter. A continuous EPDM gasket shall be mechanically attached to the aluminum frame to create a barrier around the entire perimeter of the cover and significantly reduce the amount of dirt and debris that may enter the channel frame.
- E. Hinges: Shall be specifically designed for horizontal installation and shall be through bolted to the cover with tamperproof Type 316 stainless steel lock bolts and shall be through bolted to the frame with Type 316 stainless steel bolts and locknuts.
- F. Drain Coupling: Provide a 1-1/2" (38 mm) drain coupling located in the right front corner of the channel frame, unless otherwise indicated on the plans.

Lifting Mechanisms: Manufacturer shall provide the required number and size of compression spring operators enclosed in telescopic tubes to provide, smooth, easy, and controlled cover operation throughout the entire arc of opening and to act as a check in retarding downward motion of the cover when closing. The upper tube shall be the outer tube to prevent accumulation of moisture, grit, and debris inside the lower tube assembly. The lower tube shall interlock with a flanged support shoe fastened to a formed ¼" gusset support plate.

- G. Turn/Lift Handle: A removable exterior turn/lift handle with a spring-loaded ball detent shall be provided to open the covers and the latch release shall be protected by a flush, gasketed, removable screw plug.
- H. Hardware:
 - (1) Hinges: Heavy forged aluminum hinges, each having a minimum ¼" (6.3 mm) diameter Type 316 stainless steel pin, shall be provided and shall pivot so the cover does not protrude into the channel frame.
 - (2) Covers shall be equipped with a hold open arm that automatically locks the covers in the open position.

- (3) Covers shall be fitted with a required number and size of compression spring operators. Springs shall have an electrocoated acrylic finish. Spring tubes shall be constructed of a reinforced nylon 6/6-based engineered composite material.
 - (4) A Type 316 stainless steel snap lock with fixed handle shall be mounted on the underside of the cover.
 - (5) Hardware: Shall be Type 316 stainless steel.
 - I. Finishes: Factory finish shall be mill finish aluminum with bituminous coating applied to the exterior of the frame.
 - J. Spare Keys: Contractor shall furnish three (3) door keys for each door to the Department of Water at the completion of the project.
- 6.09 INSPECTION: Verify that the vault access door installation will not disrupt other trades. Verify that the substrate is dry, clean, and free of foreign matter. Report and correct defects prior to any installation.
- 6.10 INSTALLATION:
- A. Submit shop drawing for review and approval before fabrication.
 - B. The Contractor shall check as-built conditions and verify the manufacturer's vault access door details for accuracy to fit the application prior to fabrication. The Contractor shall comply with the vault access door manufacturer's installation instructions.
 - C. The Contractor shall furnish mechanical fasteners consistent with the vault access door manufacturer's instructions.
- 6.11 PAYMENT: Payment for ALUMINUM HORIZONTAL ACCESS DOORS shall not be made separately; the compensation shall be considered incidental to the various items of the Offer for which it is a part of.

END OF SECTION

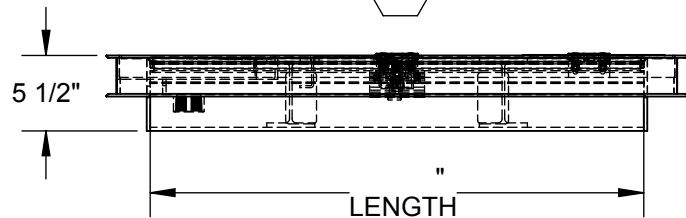
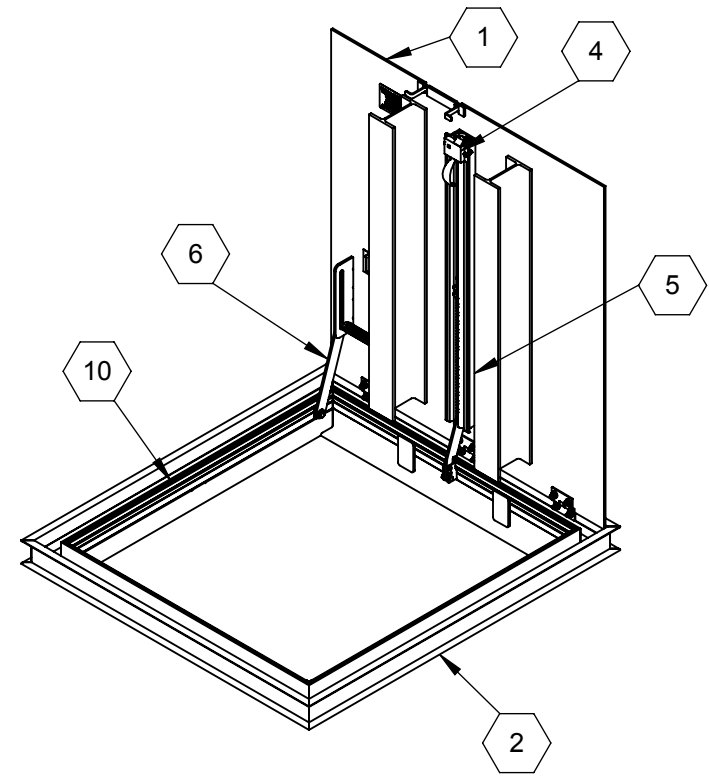
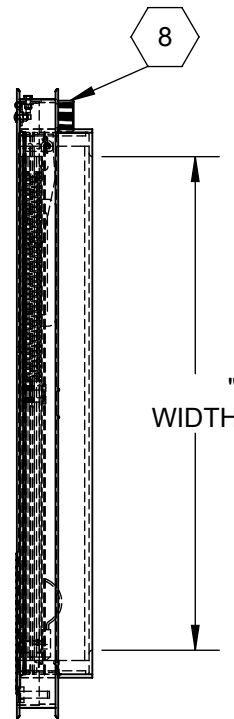
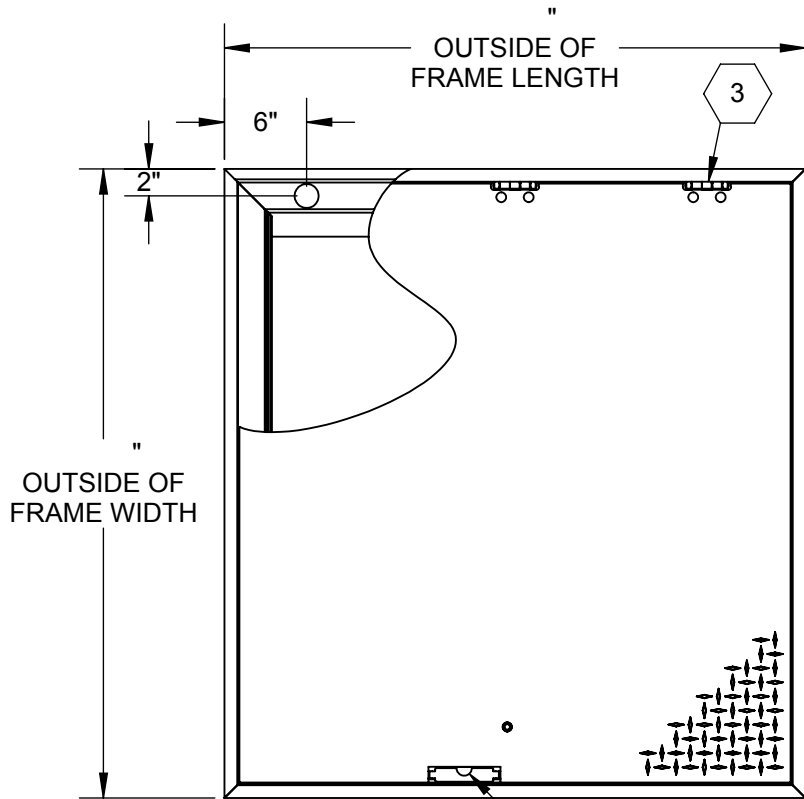

SPECIFICATIONS:

- ① **DOOR:**
ALUMINUM 1/4" DIAMOND PLATE, MILL FINISH WITH AN H20 LOAD RATING FOR INFREQUENT LOW SPEED TRAFFIC WITH A MAX SPAN DEFLECTION OF L/150
- ② **FRAME:**
ALUMINUM, 1/4" EXTRUSION, GRAY PRIMER FINISH ON EXTERIOR SURFACES THAT COME INTO CONTACT WITH CONCRETE
- ③ **HINGES:** TYPE 316 STAINLESS STEEL
- ④ **SLAM LATCH:**
TYPE 316 STAINLESS STEEL WITH INSIDE LEVER HANDLE AND OUTSIDE REMOVABLE HANDLE
- ⑤ **COUNTER-BALANCE SPRING:**
ENCLOSED, TYPE 17-7 SST SPRING
- ⑥ **HOLD-OPEN ARM:**
TYPE 316 STAINLESS STEEL WITH RED VINYL GRIP HANDLE

- ⑦ **FLUSH LIFT HANDLE:** TYPE 316 STAINLESS STEEL
- ⑧ **DRAINAGE COUPLING:** 1-1/2"
- ⑨ **FLUSH TYPE PLUG SEAL:** TYPE 316 STAINLESS STEEL
- ⑩ **GASKET:** EPDM

FLOOR DOOR SIZE:

PROPRIETARY AND CONFIDENTIAL: THE INFORMATION CONTAINED IN THIS DRAWING IS THE SOLE PROPERTY OF BABCOCK-DAVIS. ANY REPRODUCTION IN PART OR AS A WHOLE WITHOUT THE WRITTEN PERMISSION OF BABCOCK-DAVIS IS PROHIBITED.

PROJECT:				
ARCHITECT:				
CONTRACTOR:				
QTY:				
PART#:				
	TITLE: FD, Drainable H20, Sngl Dr, Alum, 1/4" Dmd, Mill, Gutter Frame, Gray Primer, Cast-In			
9300 73rd Avenue North, Brooklyn Park, MN 55428				
NAME	DATE	SIZE	DWG. NO.	REV
DRAWN BES	4/11/19	A	Babcock FD BFFDHA_X_SFL ShpDr	A
RELEASED BES	4/11/19	WEIGHT:	SHEET 1 OF 2	

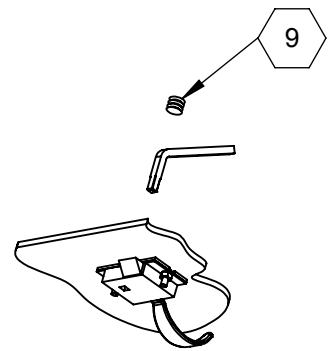
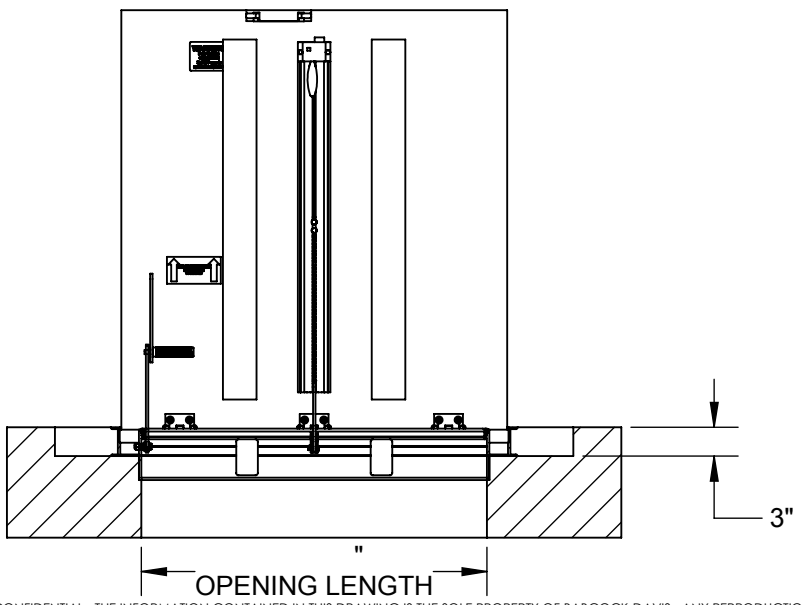
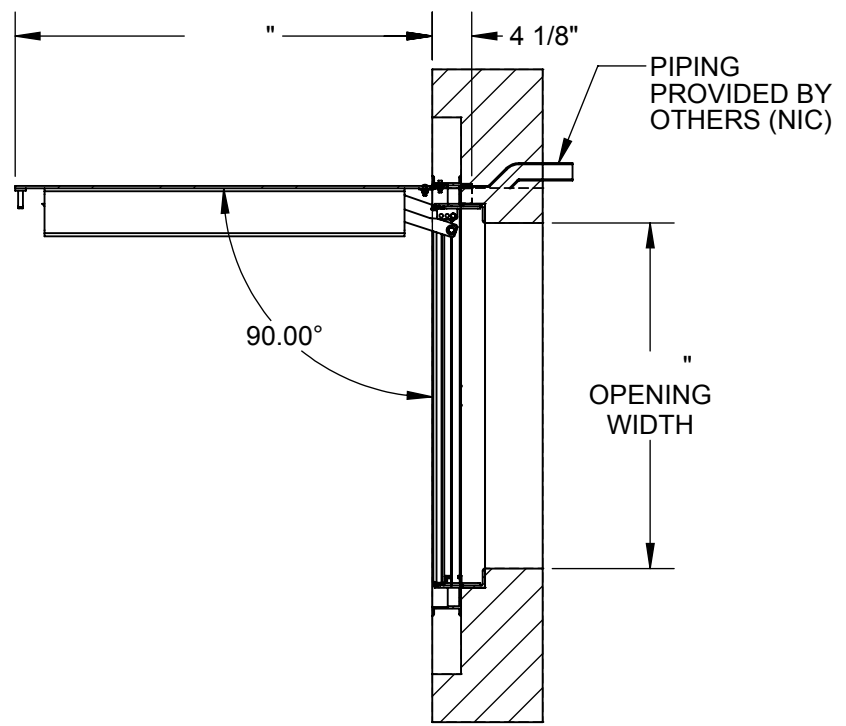
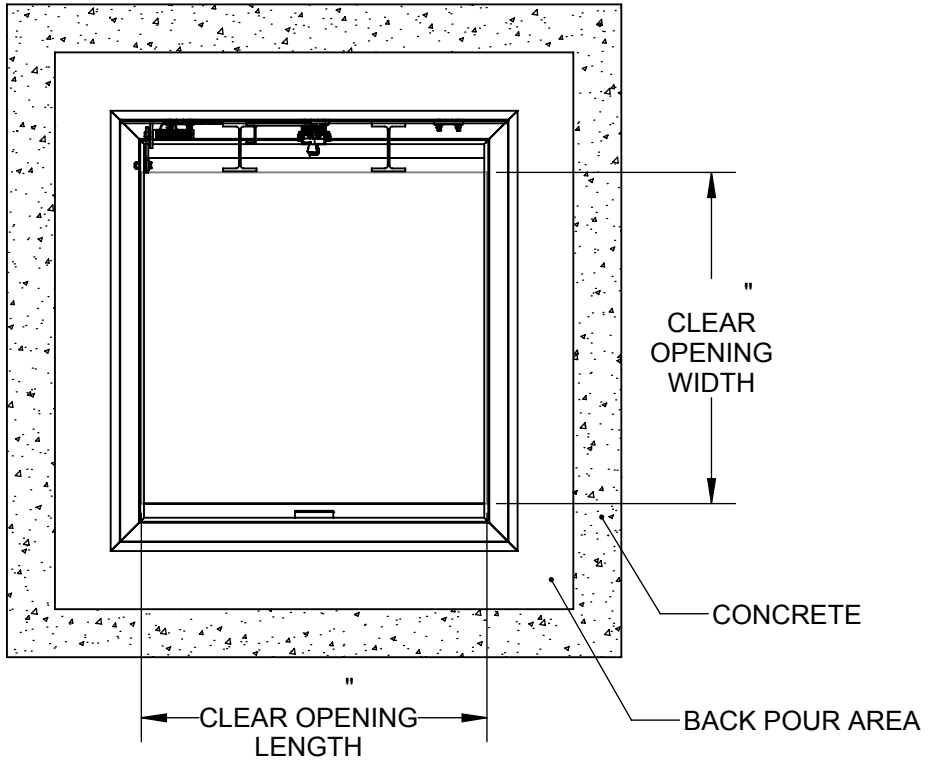

SLAM LATCH DETAIL

				TITLE: FD, Drainable H20, Sngl Dr, Alum, 1/4" Dmd, Mill, Gutter Frame, Gray Primer, Cast-In	
9300 73rd Avenue North Brooklyn Park, MN 55428					
	NAME	DATE	SIZE	DWG. NO.	REV
DRAWN	BES	4/11/19	A	Babcock FD BFDDHA_X_SFL ShpDr	A
RELEASED	BES	4/11/19	WEIGHT:	SHEET 2 OF 2	

PROPRIETARY AND CONFIDENTIAL: THE INFORMATION CONTAINED IN THIS DRAWING IS THE SOLE PROPERTY OF BABCOCK-DAVIS. ANY REPRODUCTION IN PART OR AS A WHOLE WITHOUT THE WRITTEN PERMISSION OF BABCOCK-DAVIS IS PROHIBITED.